

Standard Technical Guide 2.0

Architect/Designer/Contractor

- HVAC Supply and Return Grilles
- Return Air Filter Frames
- Hinged Access Panels
- Control Panel Boxes
- Baseboard Registers
- Lay-In Registers and Grilles
- High Velocity Supply Registers
- Inserts and Architectural Panels
- Add On Accessories



Powder Coated Finish

Screw Holes Optional

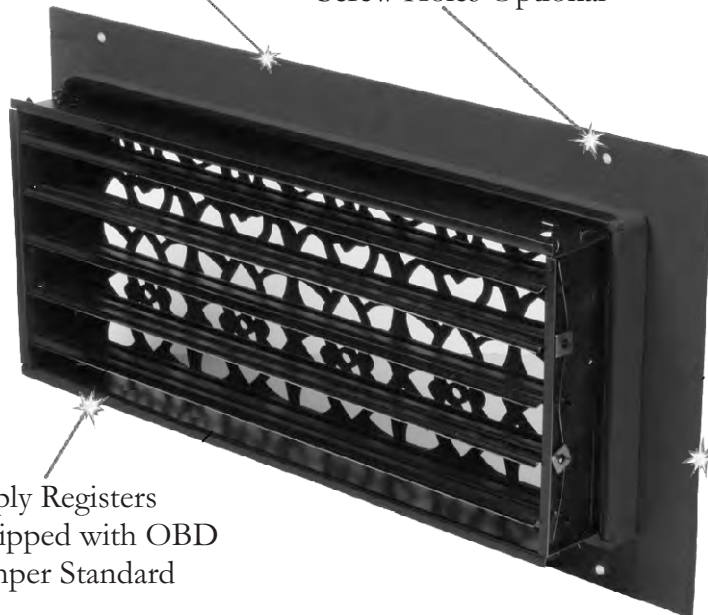

Supply Registers
Equipped with OBD
Damper Standard

Supply Registers, and Return Grilles



Return Air Filter Frames



Control Panel Boxes



T-Bar Lay-In



Baseboard Registers



Hinged Access Panels

Table of contents

- Typical Air Supply.....2
- Typical Return Air Grille.....2
- Typical Return Air Filter Frame.....3
- High Velocity Air Supply.....3
- T-Bar Lay In.....4
- Baseboard Register.....4
- Hinged Access Panel.....5
- Control Panel Box.....5-6
- Air Deflector.....7
- Concealment Louvers.....7

- Charleston, and Classic Patterns.....8
- Cobblestone, and Contemporary Patterns.....9
- Corinthian, and Expo Patterns.....10
- Gothic, and Herringbone Patterns.....11
- Mission, and New Classic Patterns.....12
- Omni, and Pinecone Patterns.....13
- Presidential, and Regency Patterns.....14
- Renaissance, and Royal Palm Patterns.....15
- Santa Fe, and Square Patterns.....16
- Stonewall, and Traditional Patterns.....17
- Tuscan, and Victorian Patterns.....18
- Vine, and Vineyard Patterns.....19
- Vogue, and Medallions Patterns.....20

- Cabinet, Window, and Door Inserts.....21-22
- **How to Measure**.....23

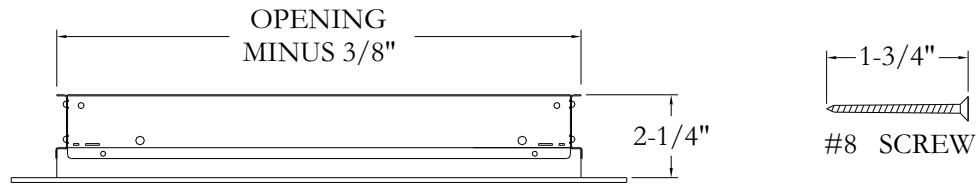
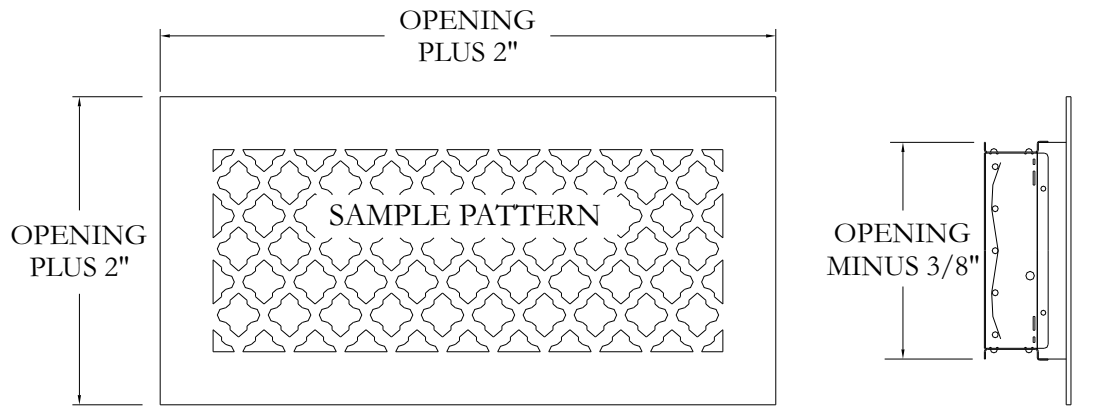

MATERIAL: 11 GAUGE STEEL
 ABOVE DIMENSIONS ARE IN INCHES
 FINISH: TO BE DETERMINED
 OVERALL OPENNESS, VARIES WITH PATTERN
 OPENNESS: VARIES

| | |
|----------|----------|
| SCALE | NONE |
| DRAWN | DH |
| DATE | 10-18-06 |
| Q.A. | |
| COMMENTS | |

TYPICAL AIR SUPPLY

THIS INFORMATION CONTAINED IN THIS DRAWING IS THE SOLE PROPERTY OF STEELCREST CORPORATION. ANY REPRODUCTION IN PART OR AS A WHOLE WITHOUT WRITTEN PERMISSION OF STEELCREST CORPORATION IS PROHIBITED

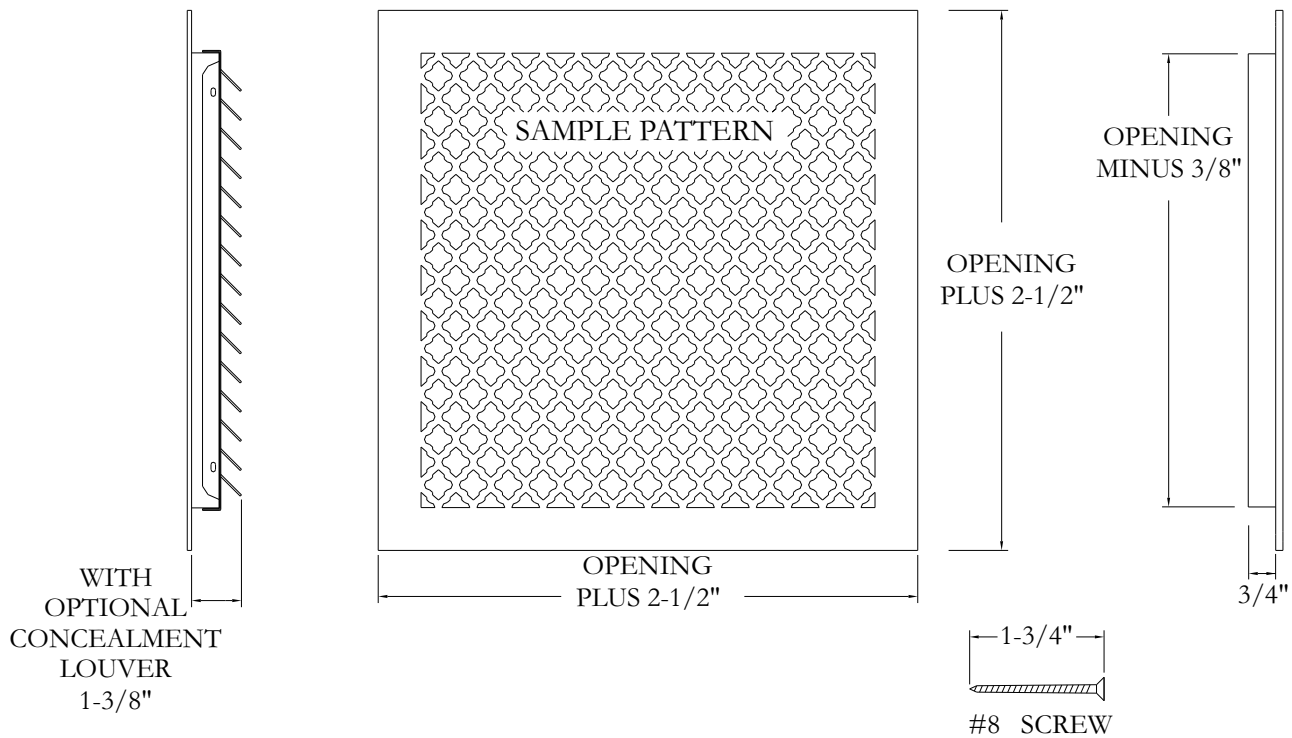

MATERIAL: 11 GAUGE STEEL
 ABOVE DIMENSIONS ARE IN INCHES
 FINISH: TO BE DETERMINED
 OVERALL OPENNESS, VARIES WITH PATTERN
 OPENNESS: VARIES

| | |
|----------|----------|
| SCALE | NONE |
| DRAWN | DH |
| DATE | 10-18-06 |
| Q.A. | |
| COMMENTS | |

TYPICAL RETURN-AIR GRILLE

THIS INFORMATION CONTAINED IN THIS DRAWING IS THE SOLE PROPERTY OF STEELCREST CORPORATION. ANY REPRODUCTION IN PART OR AS A WHOLE WITHOUT WRITTEN PERMISSION OF STEELCREST CORPORATION IS PROHIBITED

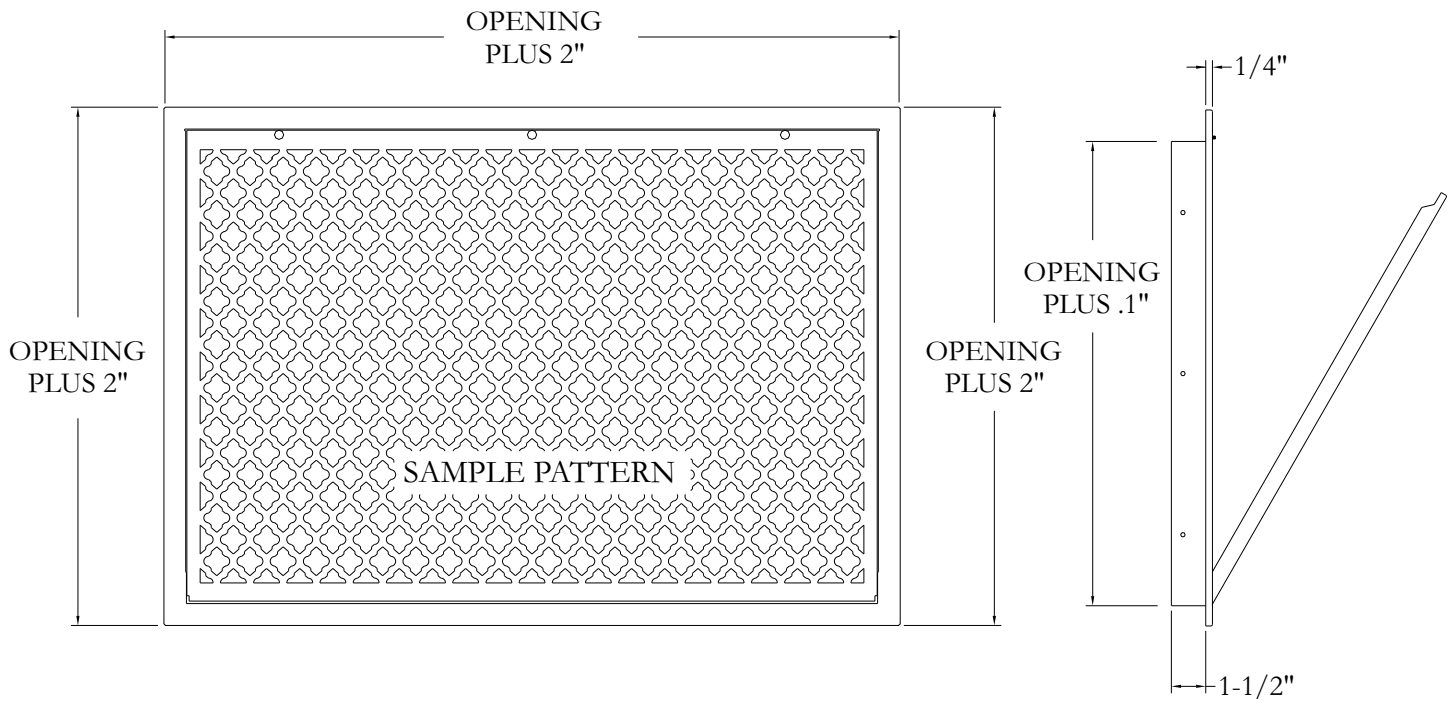

MATERIAL: 18 GAUGE STEEL
 ABOVE DIMENSIONS ARE IN INCHES
 FINISH: TO BE DETERMINED
 OVERALL OPENNESS, VARIES WITH PATTERN
 OPENNESS: VARIES

| | |
|----------|----------|
| SCALE | NONE |
| DRAWN | DH |
| DATE | 10-18-06 |
| Q.A. | |
| COMMENTS | |

TYPICAL RETURN-AIR FILTER FRAME

THIS INFORMATION CONTAINED IN THIS DRAWING IS THE SOLE PROPERTY OF STEELCREST CORPORATION. ANY REPRODUCTION IN PART OR AS A WHOLE WITHOUT WRITTEN PERMISSION OF STEELCREST CORPORATION IS PROHIBITED

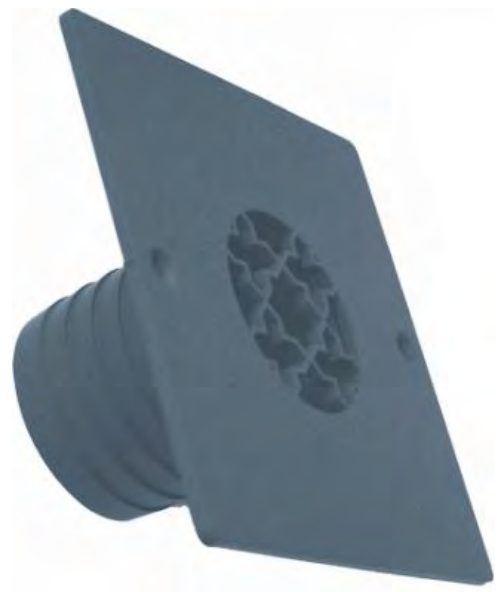
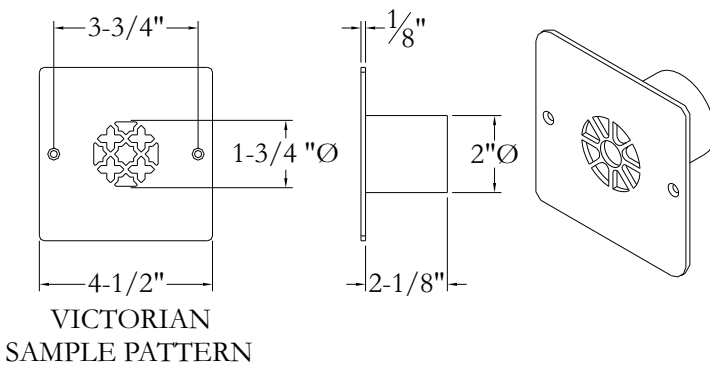
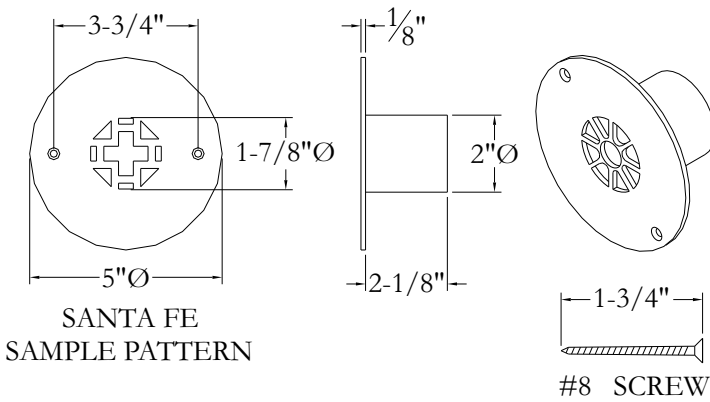

MATERIAL: 11 GAUGE STEEL
 ABOVE DIMENSIONS ARE IN INCHES
 FINISH: TO BE DETERMINED
 PATTERN OPENNESS:

| | |
|----------|--------|
| SCALE | NONE |
| DRAWN | VC |
| DATE | 8/7/12 |
| Q.A. | |
| COMMENTS | |

HIGH-VELOCITY AIR SUPPLY

THIS INFORMATION CONTAINED IN THIS DRAWING IS THE SOLE PROPERTY OF STEELCREST CORPORATION. ANY REPRODUCTION IN PART OR AS A WHOLE WITHOUT WRITTEN PERMISSION OF STEELCREST CORPORATION IS PROHIBITED

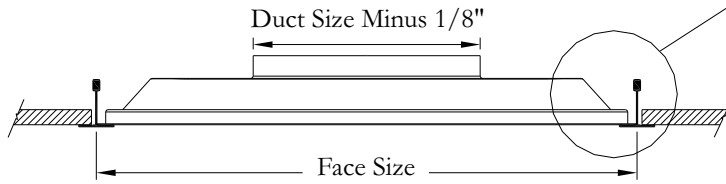
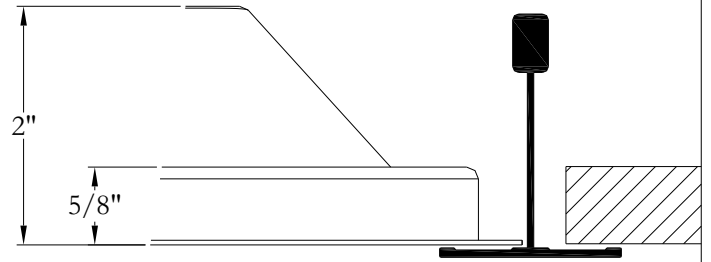
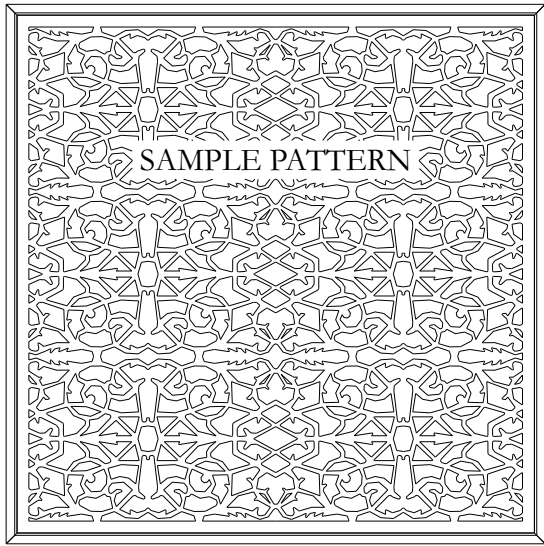

*Air Deflection Available



MATERIAL: 18 GAUGE STEEL
 ABOVE DIMENSIONS ARE IN INCHES
 FINISH: TO BE DETERMINED
 OVERALL OPENNESS, VARIES WITH PATTERN
 OPENNESS: VARIES

| | |
|----------|----------|
| SCALE | NONE |
| DRAWN | DH |
| DATE | 10-18-06 |
| Q.A. | |
| COMMENTS | |

T-BAR LAY-IN GRILLE

THIS INFORMATION CONTAINED IN THIS DRAWING IS THE SOLE PROPERTY OF STEELCREST CORPORATION. ANY REPRODUCTION IN PART OR AS A WHOLE WITHOUT WRITTEN PERMISSION OF STEELCREST CORPORATION IS PROHIBITED

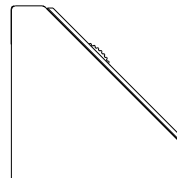
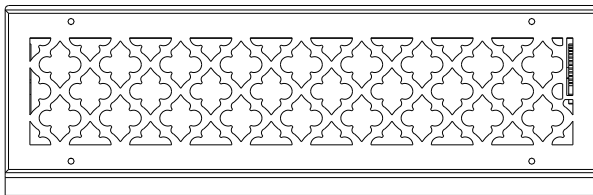
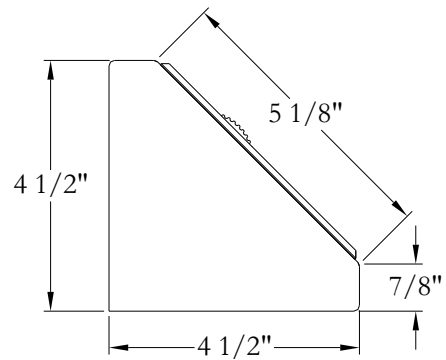
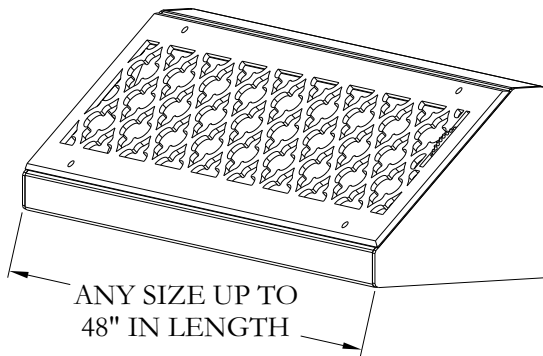

MATERIAL: 11 GAUGE STEEL
 ABOVE DIMENSIONS ARE IN INCHES
 FINISH: TO BE DETERMINED
 OVERALL OPENNESS, VARIES WITH PATTERN
 OPENNESS: VARIES

| | |
|----------|----------|
| SCALE | NONE |
| DRAWN | DH |
| DATE | 10-18-06 |
| Q.A. | |
| COMMENTS | |

BASEBOARD REGISTER

THIS INFORMATION CONTAINED IN THIS DRAWING IS THE SOLE PROPERTY OF STEELCREST CORPORATION. ANY REPRODUCTION IN PART OR AS A WHOLE WITHOUT WRITTEN PERMISSION OF STEELCREST CORPORATION IS PROHIBITED

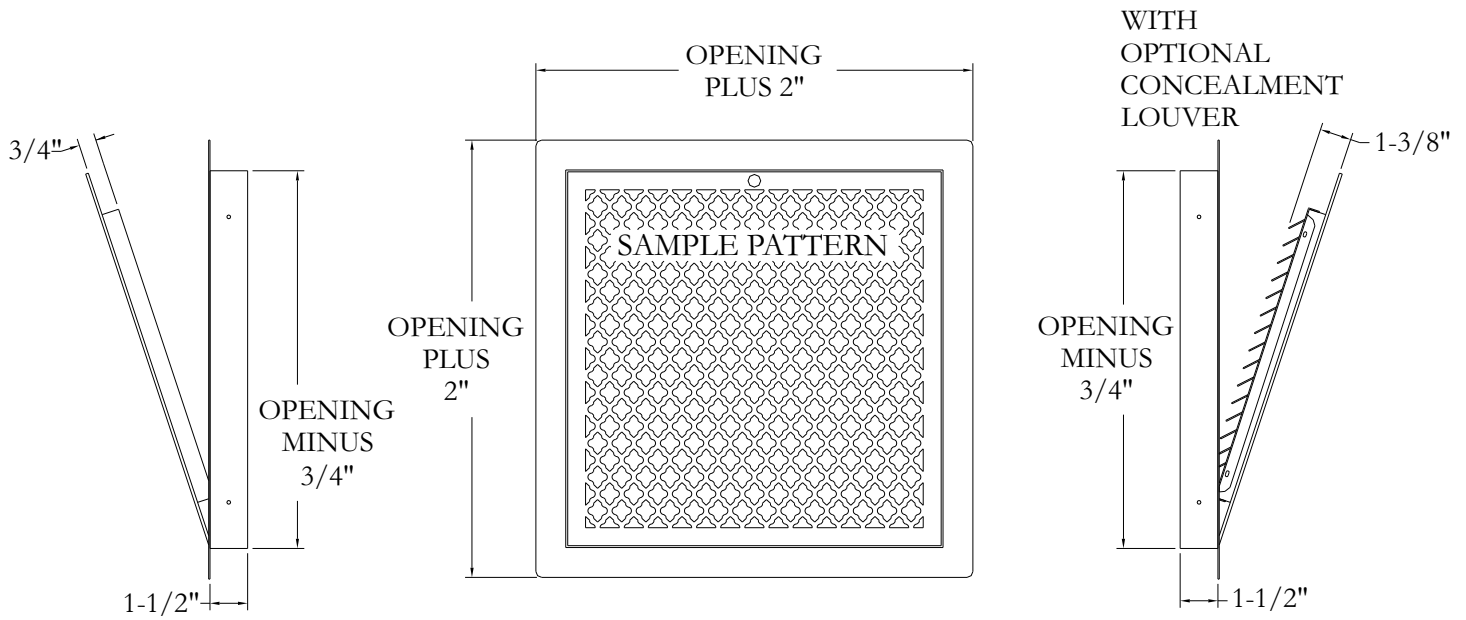

MATERIAL: 11 GAUGE STEEL
 ABOVE DIMENSIONS ARE IN INCHES
 FINISH: TO BE DETERMINED
 OVERALL OPENNESS, VARIES WITH PATTERN
 OPENNESS: VARIES

| | |
|----------|----------|
| SCALE | NONE |
| DRAWN | DH |
| DATE | 10-18-06 |
| Q.A. | |
| COMMENTS | |

HINGED ACCESS PANEL

THIS INFORMATION CONTAINED IN THIS DRAWING IS THE SOLE PROPERTY OF STEELCREST CORPORATION. ANY REPRODUCTION IN PART OR AS A WHOLE WITHOUT WRITTEN PERMISSION OF STEELCREST CORPORATION IS PROHIBITED

DRYWALL ANCHOR

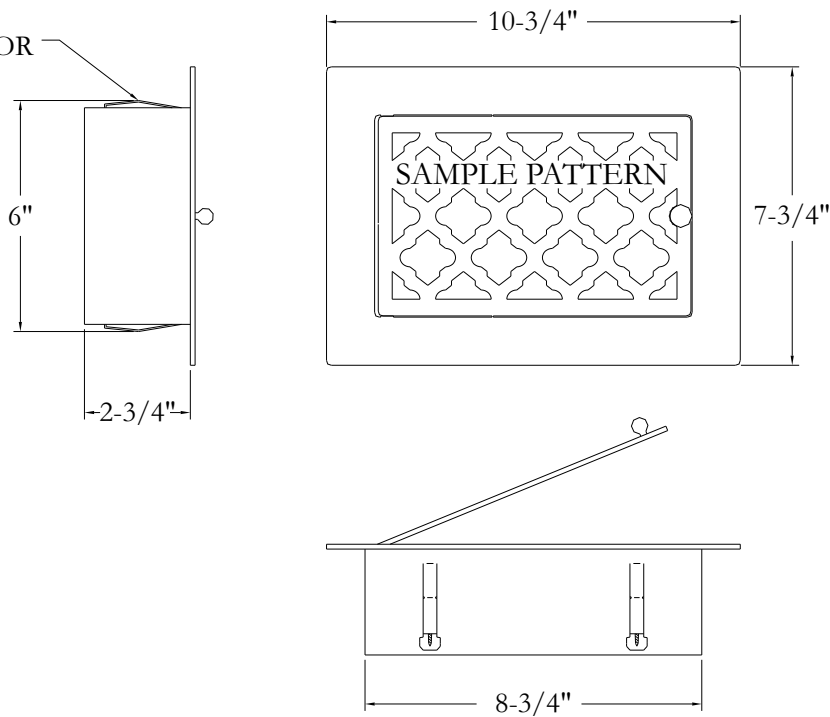

MATERIAL: 11 GAUGE STEEL
 ABOVE DIMENSIONS ARE IN INCHES
 FINISH: TO BE DETERMINED
 OVERALL OPENNESS, VARIES WITH PATTERN

| | |
|----------|----------|
| SCALE | NONE |
| DRAWN | DH |
| DATE | 10-18-06 |
| Q.A. | |
| COMMENTS | |

CONTROL PANEL BOX

THIS INFORMATION CONTAINED IN THIS DRAWING IS THE SOLE PROPERTY OF STEELCREST CORPORATION. ANY REPRODUCTION IN PART OR AS A WHOLE WITHOUT WRITTEN PERMISSION OF STEELCREST CORPORATION IS PROHIBITED

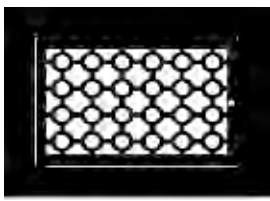

Castle

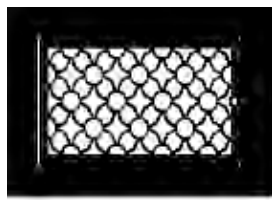

Expo



Mountain

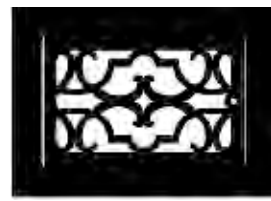

Renaissance



Traditional



Classic

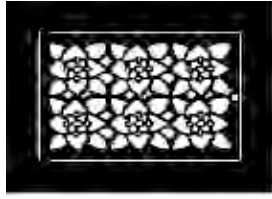

Floral

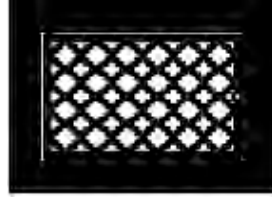

New Classic

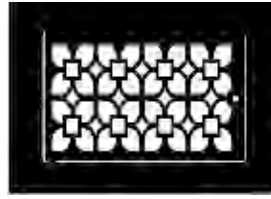

Royal Palm

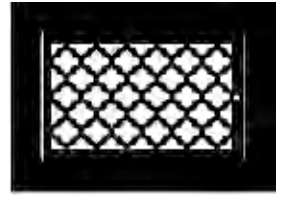

Tuscan

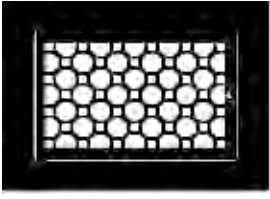

Cobblestone



Gothic

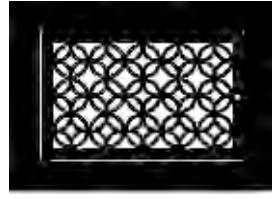

Omni

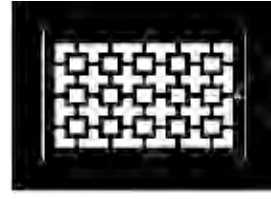

Santa Fe



Victorian

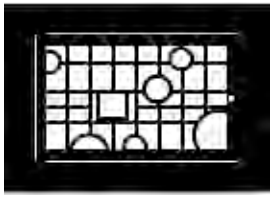

Contemporary



Herringbone



Pinecone

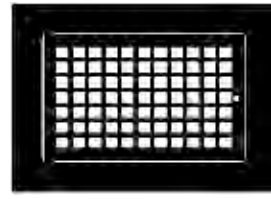

Square



Vine



Corinthian

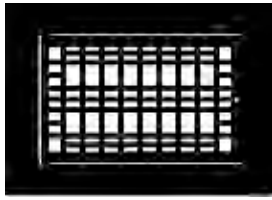

Mission



Presidential

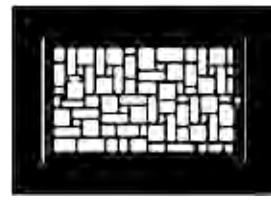

Stone Wall



Vineyard

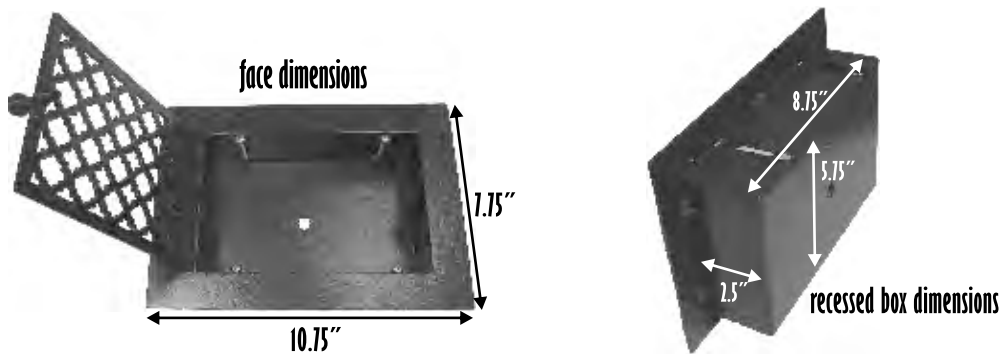

SteelCrest recommends that a licensed electrical contractor is consulted for proper disconnection an/or installation of thermostat, security systems and other types of electrical systems.

How to Measure for the Control Panel Box

1. Measure the opening currently in the wall (remove the existing thermostat if necessary); or ask your contractor.
2. Thermostat Box standard dimensions including flange are: Depth = 2.625" Width = 10.75" Height = 7.75"
3. The recessed box standard dimensions are: Depth = 2.5" Width = 8.75" Height = 5.75"
4. The flange dimension is 1" each side which conceals the opening.
5. Steel thickness is .125" for door and flange.
6. Surface-mounted thermostat panels, or non-standard dimension requirements can also be manufactured.
7. Thermostat Box slides into opening and locks into place with screw-adjusted wing clamps below mounting surface.

RECTANGLE TYPE

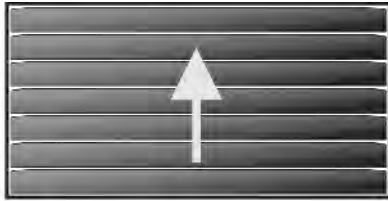

1 Way "H"



SQUARE TYPE

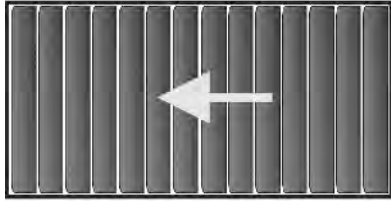

1 Way "V"

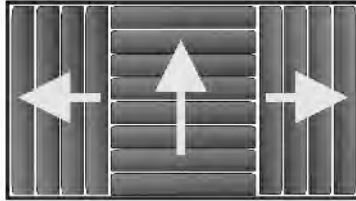

3 Way



SQ 1 Way



SQ 3 Way

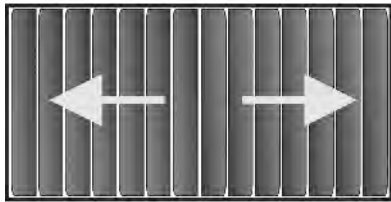

2 Way

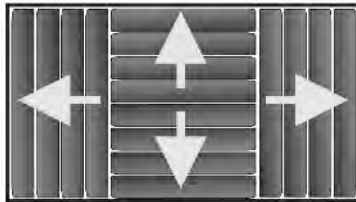

4 Way



SQ 2 Way

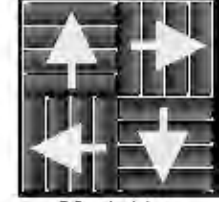

SQ 4 Way

AIR DEFLECTOR



MATERIAL: 18 GAUGE STEEL
 ABOVE DIMENSIONS ARE IN INCHES
 FINISH: TO BE DETERMINED

PROJECT:

| | |
|----------|----------|
| SCALE | NONE |
| DRAWN | DL |
| DATE | 10-18-06 |
| Q.A. | |
| COMMENTS | |

THIS INFORMATION CONTAINED IN THIS DRAWING IS THE SOLE PROPERTY OF STEELCREST CORPORATION. ANY REPRODUCTION IN PART OR AS A WHOLE WITHOUT WRITTEN PERMISSION OF STEELCREST CORPORATION IS PROHIBITED

GRILLE SHOWN WITHOUT CONCEALMENT LOUVER

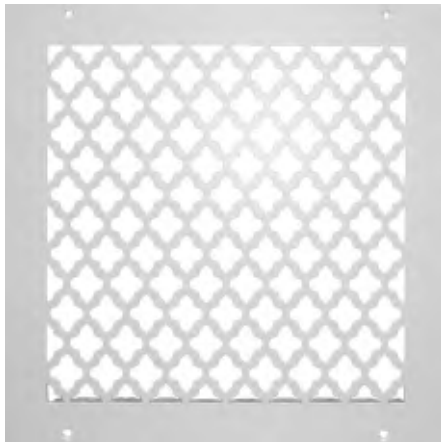

TUSCAN SAMPLE PATTERN



TYPICAL CONCEALMENT LOUVER INSTALLATION

GRILLE SHOWN WITH CONCEALMENT LOUVER

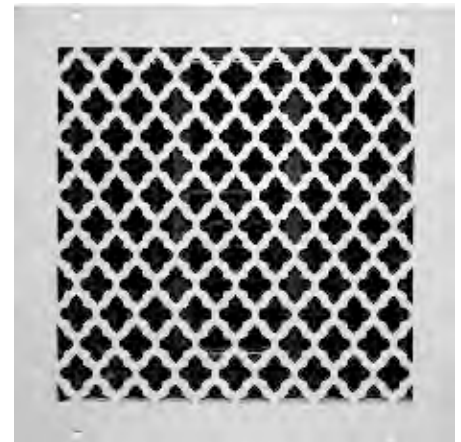

TUSCAN SAMPLE PATTERN

CONCEALMENT LOUVERS



MATERIAL: 18 GAUGE STEEL
 ABOVE DIMENSIONS ARE IN INCHES
 FINISH: TO BE DETERMINED

PROJECT:

| | |
|----------|----------|
| SCALE | NONE |
| DRAWN | DL |
| DATE | 10-18-06 |
| Q.A. | |
| COMMENTS | |

THIS INFORMATION CONTAINED IN THIS DRAWING IS THE SOLE PROPERTY OF STEELCREST CORPORATION. ANY REPRODUCTION IN PART OR AS A WHOLE WITHOUT WRITTEN PERMISSION OF STEELCREST CORPORATION IS PROHIBITED

PATTERN DETAIL MEASUREMENTS

NOTE: MEASUREMENTS ARE APPROXIMATE AND WILL VARY WITH REGISTER SIZE.

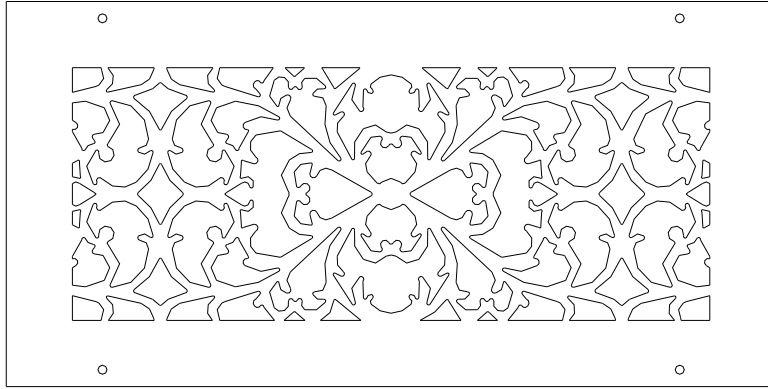
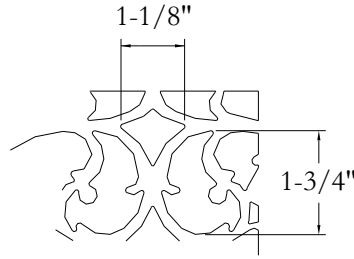

| Air Flow Performance Data | | | | | |
|-------------------------------|--------------|--------------|--------------|---------------|---------------|
| Velocity Static Pressure | 250 0.009 | 500 0.018 | 750 0.027 | 1000 0.036 | 1500 0.055 |
| Size | CFM | | | | |
| 6x6 .25 ft ² | 45 | 92 | 135 | 185 | 275 |
| 8x8 .44 ft ² | 80 | 160 | 240 | 320 | 480 |
| 10x10 .69 ft ² | 125 | 250 | 375 | 500 | 750 |
| 12x12 1.0 ft ² | 180 | 360 | 540 | 720 | 1100 |
| 14x14 1.36 ft ² | 245 | 490 | 735 | 980 | 1470 |
| 8x6 .33 ft ² | 60 | 120 | 180 | 240 | 360 |
| 10x6 .42 ft ² | 75 | 150 | 225 | 300 | 450 |
| 12x6 .5 ft ² | 90 | 180 | 270 | 360 | 540 |
| 14x6 .58 ft ² | 105 | 210 | 315 | 420 | 630 |
| 16x6 .67 ft ² | 120 | 240 | 360 | 480 | 720 |
| 18x6 .75 ft ² | 135 | 270 | 405 | 540 | 810 |
| 20x6 .83 ft ² | 150 | 300 | 450 | 600 | 900 |
| 10x8 .56 ft ² | 100 | 200 | 300 | 400 | 600 |
| 12x8 .67 ft ² | 120 | 240 | 360 | 480 | 720 |
| 14x8 .78 ft ² | 140 | 280 | 420 | 560 | 840 |
| 8x4 .22 ft ² | 40 | 80 | 120 | 160 | 240 |
| 10x4 .28 ft ² | 50 | 100 | 150 | 200 | 300 |
| 12x4 .33 ft ² | 60 | 120 | 180 | 240 | 360 |



MATERIAL: 11 GAUGE STEEL
 ABOVE DIMENSIONS ARE IN INCHES
 FINISH: TO BE DETERMINED
 PATTERN OPENNESS: 65%

| | |
|----------|----------|
| SCALE | NONE |
| DRAWN | DH |
| DATE | 10-18-06 |
| Q.A. | |
| COMMENTS | |

CHARLESTON DESIGN

THIS INFORMATION CONTAINED IN THIS DRAWING IS THE SOLE PROPERTY OF STEELCREST CORPORATION. ANY REPRODUCTION IN PART OR AS A WHOLE WITHOUT WRITTEN PERMISSION OF STEELCREST CORPORATION IS PROHIBITED

PATTERN DETAIL MEASUREMENTS

NOTE: MEASUREMENTS ARE APPROXIMATE AND WILL VARY WITH REGISTER SIZE.

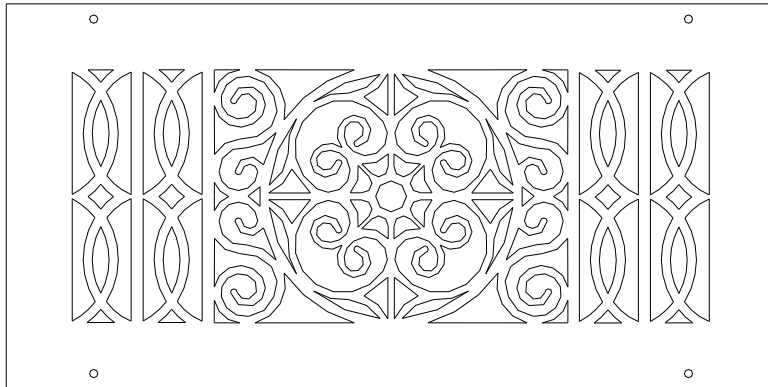
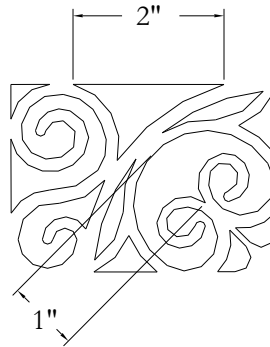

| Air Flow Performance Data | | | | | |
|-------------------------------|--------------|--------------|--------------|---------------|---------------|
| Velocity Static Pressure | 250 0.009 | 500 0.018 | 750 0.027 | 1000 0.036 | 1500 0.055 |
| Size | CFM | | | | |
| 6x6 .25 ft ² | 45 | 92 | 135 | 185 | 275 |
| 8x8 .44 ft ² | 80 | 160 | 240 | 320 | 480 |
| 10x10 .69 ft ² | 125 | 250 | 375 | 500 | 750 |
| 12x12 1.0 ft ² | 180 | 360 | 540 | 720 | 1100 |
| 14x14 1.36 ft ² | 245 | 490 | 735 | 980 | 1470 |
| 8x6 .33 ft ² | 60 | 120 | 180 | 240 | 360 |
| 10x6 .42 ft ² | 75 | 150 | 225 | 300 | 450 |
| 12x6 .5 ft ² | 90 | 180 | 270 | 360 | 540 |
| 14x6 .58 ft ² | 105 | 210 | 315 | 420 | 630 |
| 16x6 .67 ft ² | 120 | 240 | 360 | 480 | 720 |
| 18x6 .75 ft ² | 135 | 270 | 405 | 540 | 810 |
| 20x6 .83 ft ² | 150 | 300 | 450 | 600 | 900 |
| 10x8 .56 ft ² | 100 | 200 | 300 | 400 | 600 |
| 12x8 .67 ft ² | 120 | 240 | 360 | 480 | 720 |
| 14x8 .78 ft ² | 140 | 280 | 420 | 560 | 840 |
| 8x4 .22 ft ² | 40 | 80 | 120 | 160 | 240 |
| 10x4 .28 ft ² | 50 | 100 | 150 | 200 | 300 |
| 12x4 .33 ft ² | 60 | 120 | 180 | 240 | 360 |



MATERIAL: 11 GAUGE STEEL
 ABOVE DIMENSIONS ARE IN INCHES
 FINISH: TO BE DETERMINED
 PATTERN OPENNESS: 65%

| | |
|----------|----------|
| SCALE | NONE |
| DRAWN | DH |
| DATE | 10-18-06 |
| Q.A. | |
| COMMENTS | |

CLASSIC DESIGN

THIS INFORMATION CONTAINED IN THIS DRAWING IS THE SOLE PROPERTY OF STEELCREST CORPORATION. ANY REPRODUCTION IN PART OR AS A WHOLE WITHOUT WRITTEN PERMISSION OF STEELCREST CORPORATION IS PROHIBITED

PATTERN DETAIL MEASUREMENTS

NOTE: MEASUREMENTS ARE APPROXIMATE AND WILL VARY WITH REGISTER SIZE.

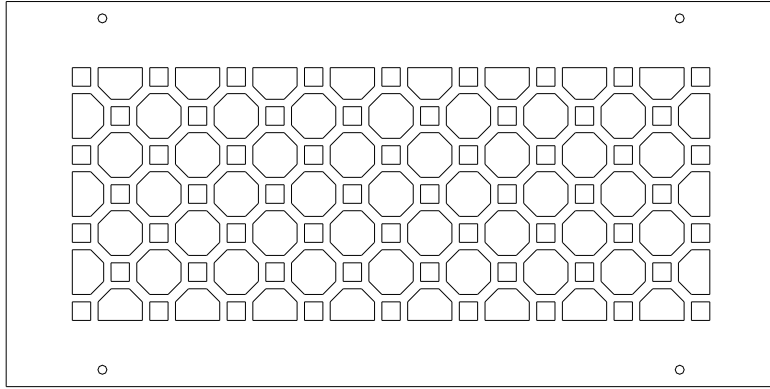
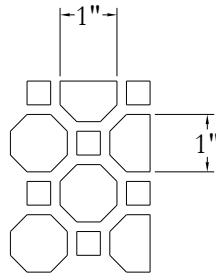

| Air Flow Performance Data | | | | | |
|----------------------------|-----------|-----------|-----------|------------|------------|
| Velocity Static Pressure | 250 0.009 | 500 0.018 | 750 0.027 | 1000 0.036 | 1500 0.055 |
| Size | CFM | | | | |
| 6x6 .25 ft ² | 47 | 97 | 141 | 205 | 311 |
| 8x8 .44 ft ² | 85 | 172 | 255 | 362 | 502 |
| 10x10 .69 ft ² | 130 | 265 | 390 | 544 | 790 |
| 12x12 1.0 ft ² | 187 | 380 | 561 | 740 | 1195 |
| 14x14 1.36 ft ² | 252 | 512 | 742 | 1005 | 1510 |
| 8x6 .33 ft ² | 65 | 131 | 195 | 257 | 382 |
| 10x6 .42 ft ² | 82 | 162 | 232 | 332 | 470 |
| 12x6 .5 ft ² | 97 | 195 | 270 | 360 | 540 |
| 14x6 .58 ft ² | 112 | 218 | 315 | 431 | 655 |
| 16x6 .67 ft ² | 131 | 253 | 374 | 515 | 787 |
| 18x6 .75 ft ² | 147 | 285 | 405 | 540 | 810 |
| 20x6 .83 ft ² | 162 | 318 | 462 | 620 | 932 |
| 10x8 .56 ft ² | 108 | 216 | 332 | 447 | 661 |
| 12x8 .67 ft ² | 131 | 253 | 374 | 500 | 762 |
| 14x8 .78 ft ² | 153 | 292 | 445 | 590 | 865 |
| 8x4 .22 ft ² | 43 | 95 | 120 | 160 | 240 |
| 10x4 .28 ft ² | 55 | 112 | 171 | 221 | 334 |
| 12x4 .33 ft ² | 65 | 131 | 195 | 257 | 382 |



MATERIAL: 11 GAUGE STEEL
 ABOVE DIMENSIONS ARE IN INCHES
 FINISH: TO BE DETERMINED

PATTERN OPENNESS: 67%

| | |
|----------|----------|
| SCALE | NONE |
| DRAWN | DH |
| DATE | 10-18-06 |
| Q.A. | |
| COMMENTS | |

COBBLESTONE DESIGN

THIS INFORMATION CONTAINED IN THIS DRAWING IS THE SOLE PROPERTY OF STEELCREST CORPORATION. ANY REPRODUCTION IN PART OR AS A WHOLE WITHOUT WRITTEN PERMISSION OF STEELCREST CORPORATION IS PROHIBITED

PATTERN DETAIL MEASUREMENTS

NOTE: MEASUREMENTS ARE APPROXIMATE AND WILL VARY WITH REGISTER SIZE.

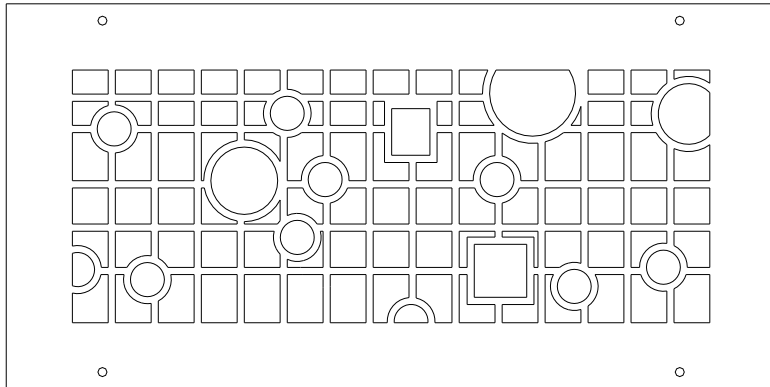
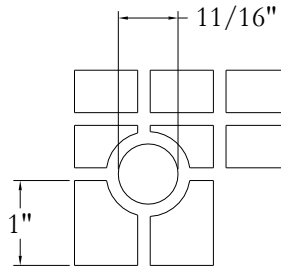

| Air Flow Performance Data | | | | | |
|----------------------------|-----------|-----------|-----------|------------|------------|
| Velocity Static Pressure | 250 0.009 | 500 0.018 | 750 0.027 | 1000 0.036 | 1500 0.055 |
| Size | CFM | | | | |
| 6x6 .25 ft ² | 45 | 92 | 135 | 185 | 275 |
| 8x8 .44 ft ² | 80 | 160 | 240 | 320 | 480 |
| 10x10 .69 ft ² | 125 | 250 | 375 | 500 | 750 |
| 12x12 1.0 ft ² | 180 | 360 | 540 | 720 | 1100 |
| 14x14 1.36 ft ² | 245 | 490 | 735 | 980 | 1470 |
| 8x6 .33 ft ² | 60 | 120 | 180 | 240 | 360 |
| 10x6 .42 ft ² | 75 | 150 | 225 | 300 | 450 |
| 12x6 .5 ft ² | 90 | 180 | 270 | 360 | 540 |
| 14x6 .58 ft ² | 105 | 210 | 315 | 420 | 630 |
| 16x6 .67 ft ² | 120 | 240 | 360 | 480 | 720 |
| 18x6 .75 ft ² | 135 | 270 | 405 | 540 | 810 |
| 20x6 .83 ft ² | 150 | 300 | 450 | 600 | 900 |
| 10x8 .56 ft ² | 100 | 200 | 300 | 400 | 600 |
| 12x8 .67 ft ² | 120 | 240 | 360 | 480 | 720 |
| 14x8 .78 ft ² | 140 | 280 | 420 | 560 | 840 |
| 8x4 .22 ft ² | 40 | 80 | 120 | 160 | 240 |
| 10x4 .28 ft ² | 50 | 100 | 150 | 200 | 300 |
| 12x4 .33 ft ² | 60 | 120 | 180 | 240 | 360 |



MATERIAL: 11 GAUGE STEEL
 ABOVE DIMENSIONS ARE IN INCHES
 FINISH: TO BE DETERMINED

PATTERN OPENNESS: 65%

| | |
|----------|----------|
| SCALE | NONE |
| DRAWN | DH |
| DATE | 10-18-06 |
| Q.A. | |
| COMMENTS | |

CONTEMPORARY DESIGN

THIS INFORMATION CONTAINED IN THIS DRAWING IS THE SOLE PROPERTY OF STEELCREST CORPORATION. ANY REPRODUCTION IN PART OR AS A WHOLE WITHOUT WRITTEN PERMISSION OF STEELCREST CORPORATION IS PROHIBITED

PATTERN DETAIL MEASUREMENTS

NOTE: MEASUREMENTS ARE APPROXIMATE AND WILL VARY WITH REGISTER SIZE.

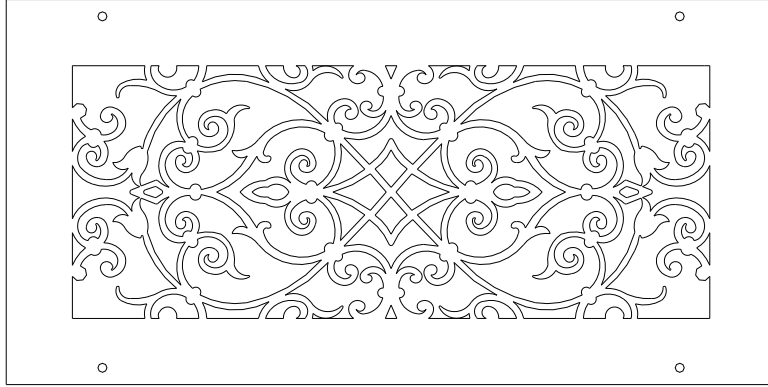
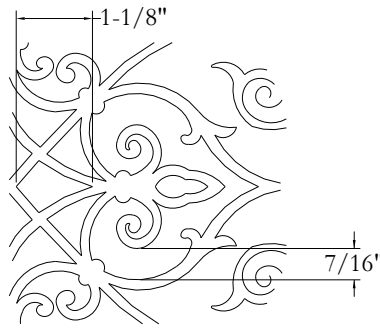

| Air Flow Performance Data | | | | | |
|-------------------------------|--------------|--------------|--------------|---------------|---------------|
| Velocity Static Pressure | 250 0.009 | 500 0.018 | 750 0.027 | 1000 0.036 | 1500 0.055 |
| Size | CFM | | | | |
| 6x6 .25 ft ² | 47 | 97 | 141 | 205 | 311 |
| 8x8 .44 ft ² | 85 | 172 | 255 | 362 | 502 |
| 10x10 .69 ft ² | 130 | 265 | 390 | 544 | 790 |
| 12x12 1.0 ft ² | 187 | 380 | 561 | 740 | 1195 |
| 14x14 1.36 ft ² | 252 | 512 | 742 | 1005 | 1510 |
| 8x6 .33 ft ² | 65 | 131 | 195 | 257 | 382 |
| 10x6 .42 ft ² | 82 | 162 | 232 | 332 | 470 |
| 12x6 .5 ft ² | 97 | 195 | 270 | 360 | 540 |
| 14x6 .58 ft ² | 112 | 218 | 315 | 431 | 655 |
| 16x6 .67 ft ² | 131 | 253 | 374 | 515 | 787 |
| 18x6 .75 ft ² | 147 | 285 | 405 | 540 | 810 |
| 20x6 .83 ft ² | 162 | 318 | 462 | 620 | 932 |
| 10x8 .56 ft ² | 108 | 216 | 332 | 447 | 661 |
| 12x8 .67 ft ² | 131 | 253 | 374 | 500 | 762 |
| 14x8 .78 ft ² | 153 | 292 | 445 | 590 | 865 |
| 8x4 .22 ft ² | 43 | 95 | 120 | 160 | 240 |
| 10x4 .28 ft ² | 55 | 112 | 171 | 221 | 334 |
| 12x4 .33 ft ² | 65 | 131 | 195 | 257 | 382 |



MATERIAL: 11 GAUGE STEEL
 ABOVE DIMENSIONS ARE IN INCHES
 FINISH: TO BE DETERMINED
 PATTERN OPENNESS: 67%

| | |
|----------|----------|
| SCALE | NONE |
| DRAWN | DH |
| DATE | 10-18-06 |
| Q.A. | |
| COMMENTS | |

CORINTHIAN DESIGN

THIS INFORMATION CONTAINED IN THIS DRAWING IS THE SOLE PROPERTY OF STEELCREST CORPORATION. ANY REPRODUCTION IN PART OR AS A WHOLE WITHOUT WRITTEN PERMISSION OF STEELCREST CORPORATION IS PROHIBITED

PATTERN DETAIL MEASUREMENTS

NOTE: MEASUREMENTS ARE APPROXIMATE AND WILL VARY WITH REGISTER SIZE.

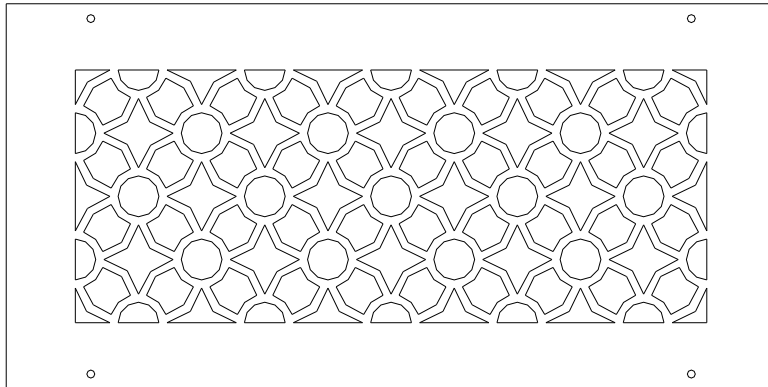
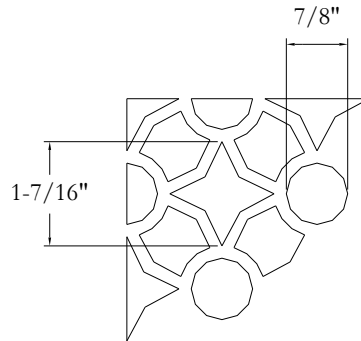

| Air Flow Performance Data | | | | | |
|-------------------------------|--------------|--------------|--------------|---------------|---------------|
| Velocity Static Pressure | 250 0.009 | 500 0.018 | 750 0.027 | 1000 0.036 | 1500 0.055 |
| Size | CFM | | | | |
| 6x6 .25 ft ² | 47 | 97 | 141 | 205 | 311 |
| 8x8 .44 ft ² | 85 | 172 | 255 | 362 | 502 |
| 10x10 .69 ft ² | 130 | 265 | 390 | 544 | 790 |
| 12x12 1.0 ft ² | 187 | 380 | 561 | 740 | 1195 |
| 14x14 1.36 ft ² | 252 | 512 | 742 | 1005 | 1510 |
| 8x6 .33 ft ² | 65 | 131 | 195 | 257 | 382 |
| 10x6 .42 ft ² | 82 | 162 | 232 | 332 | 470 |
| 12x6 .5 ft ² | 97 | 195 | 270 | 360 | 540 |
| 14x6 .58 ft ² | 112 | 218 | 315 | 431 | 655 |
| 16x6 .67 ft ² | 131 | 253 | 374 | 515 | 787 |
| 18x6 .75 ft ² | 147 | 285 | 405 | 540 | 810 |
| 20x6 .83 ft ² | 162 | 318 | 462 | 620 | 932 |
| 10x8 .56 ft ² | 108 | 216 | 332 | 447 | 661 |
| 12x8 .67 ft ² | 131 | 253 | 374 | 500 | 762 |
| 14x8 .78 ft ² | 153 | 292 | 445 | 590 | 865 |
| 8x4 .22 ft ² | 43 | 95 | 120 | 160 | 240 |
| 10x4 .28 ft ² | 55 | 112 | 171 | 221 | 334 |
| 12x4 .33 ft ² | 65 | 131 | 195 | 257 | 382 |



MATERIAL: 11 GAUGE STEEL
 ABOVE DIMENSIONS ARE IN INCHES
 FINISH: TO BE DETERMINED
 PATTERN OPENNESS: 67%

| | |
|----------|----------|
| SCALE | NONE |
| DRAWN | DH |
| DATE | 10-18-06 |
| Q.A. | |
| COMMENTS | |

EXPO DESIGN

THIS INFORMATION CONTAINED IN THIS DRAWING IS THE SOLE PROPERTY OF STEELCREST CORPORATION. ANY REPRODUCTION IN PART OR AS A WHOLE WITHOUT WRITTEN PERMISSION OF STEELCREST CORPORATION IS PROHIBITED

PATTERN DETAIL MEASUREMENTS

NOTE: MEASUREMENTS ARE APPROXIMATE AND WILL VARY WITH REGISTER SIZE.

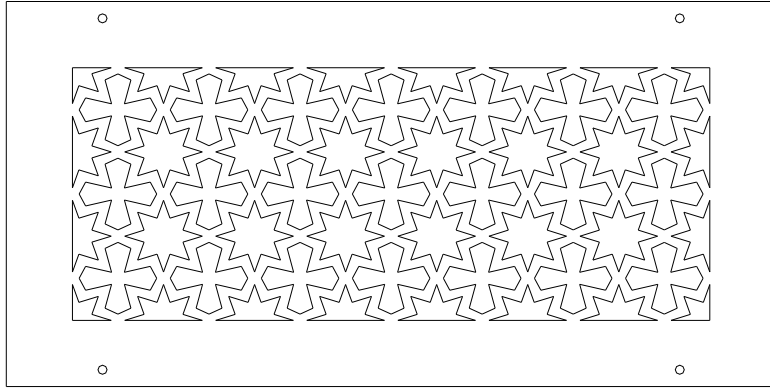
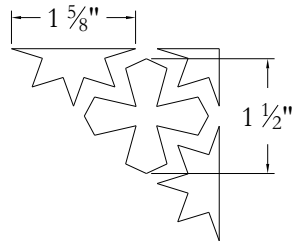

| Air Flow Performance Data | | | | | |
|----------------------------|------|-------|-------|-------|-------|
| Velocity Static Pressure | 250 | 500 | 750 | 1000 | 1500 |
| | 0.02 | 0.042 | 0.063 | 0.084 | 0.126 |
| Size | CFM | | | | |
| 6x6 .25 ft ² | 38 | 75 | 115 | 155 | 230 |
| 8x8 .44 ft ² | 68 | 135 | 205 | 270 | 405 |
| 10x10 .69 ft ² | 105 | 210 | 315 | 425 | 635 |
| 12x12 1.0 ft ² | 155 | 305 | 460 | 610 | 915 |
| 14x14 1.36 ft ² | 211 | 415 | 626 | 830 | 1245 |
| 8x6 .33 ft ² | 52 | 102 | 153 | 203 | 305 |
| 10x6 .42 ft ² | 65 | 127 | 192 | 254 | 381 |
| 12x6 .5 ft ² | 77 | 152 | 230 | 305 | 457 |
| 14x6 .58 ft ² | 90 | 178 | 268 | 356 | 534 |
| 16x6 .67 ft ² | 103 | 203 | 307 | 407 | 610 |
| 18x6 .75 ft ² | 116 | 229 | 345 | 457 | 686 |
| 20x6 .83 ft ² | 129 | 254 | 383 | 508 | 762 |
| 10x8 .56 ft ² | 86 | 169 | 256 | 339 | 508 |
| 12x8 .67 ft ² | 103 | 203 | 307 | 407 | 610 |
| 14x8 .78 ft ² | 121 | 237 | 358 | 474 | 712 |
| 8x4 .22 ft ² | 34 | 68 | 102 | 136 | 203 |
| 10x4 .28 ft ² | 43 | 85 | 128 | 169 | 254 |
| 12x4 .33 ft ² | 52 | 102 | 153 | 203 | 305 |



MATERIAL: 11 GAUGE STEEL
 ABOVE DIMENSIONS ARE IN INCHES
 FINISH: TO BE DETERMINED

PATTERN OPENNESS: 60%

| | |
|----------|----------|
| SCALE | NONE |
| DRAWN | DH |
| DATE | 10-18-06 |
| Q.A. | |
| COMMENTS | |

GOTHIC DESIGN

THIS INFORMATION CONTAINED IN THIS DRAWING IS THE SOLE PROPERTY OF STEELCREST CORPORATION. ANY REPRODUCTION IN PART OR AS A WHOLE WITHOUT WRITTEN PERMISSION OF STEELCREST CORPORATION IS PROHIBITED

PATTERN DETAIL MEASUREMENTS

NOTE: MEASUREMENTS ARE APPROXIMATE AND WILL VARY WITH REGISTER SIZE.

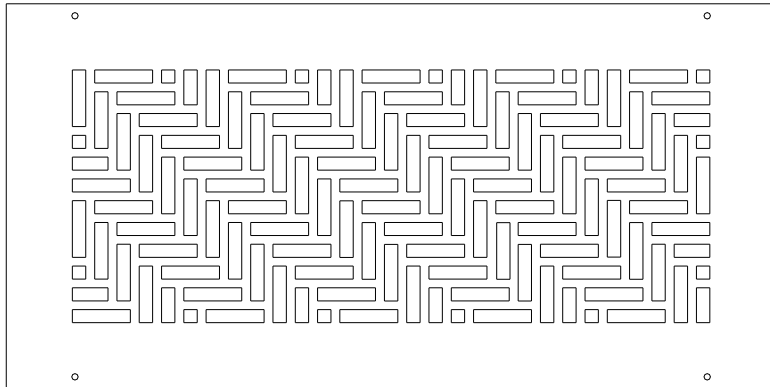
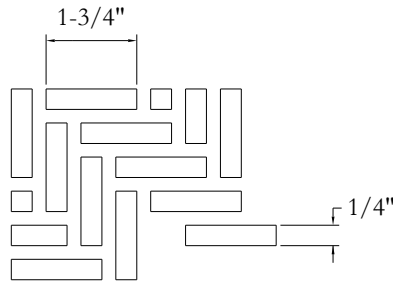

| Air Flow Performance Data | | | | | |
|----------------------------|-------|-------|--------|-------|-------|
| Velocity Static Pressure | 250 | 500 | 750 | 1000 | 1500 |
| | 0.005 | 0.011 | 0.0175 | 0.023 | 0.035 |
| Size | CFM | | | | |
| 6x6 .25 ft ² | 42 | 85 | 125 | 170 | 255 |
| 8x8 .44 ft ² | 75 | 150 | 225 | 300 | 450 |
| 10x10 .69 ft ² | 115 | 235 | 350 | 465 | 700 |
| 12x12 1.0 ft ² | 167 | 335 | 500 | 680 | 1020 |
| 14x14 1.36 ft ² | 225 | 461 | 686 | 911 | 1372 |
| 8x6 .33 ft ² | 55 | 113 | 168 | 223 | 336 |
| 10x6 .42 ft ² | 69 | 141 | 210 | 279 | 420 |
| 12x6 .5 ft ² | 83 | 169 | 252 | 335 | 504 |
| 14x6 .58 ft ² | 97 | 197 | 294 | 391 | 588 |
| 16x6 .67 ft ² | 110 | 226 | 336 | 446 | 672 |
| 18x6 .75 ft ² | 124 | 254 | 378 | 502 | 756 |
| 20x6 .83 ft ² | 138 | 282 | 420 | 558 | 840 |
| 10x8 .56 ft ² | 92 | 188 | 280 | 372 | 560 |
| 12x8 .67 ft ² | 110 | 226 | 336 | 446 | 672 |
| 14x8 .78 ft ² | 129 | 263 | 392 | 521 | 784 |
| 8x4 .22 ft ² | 37 | 75 | 112 | 149 | 224 |
| 10x4 .28 ft ² | 46 | 94 | 140 | 186 | 280 |
| 12x4 .33 ft ² | 55 | 113 | 168 | 223 | 336 |



MATERIAL: 11 GAUGE STEEL
 ABOVE DIMENSIONS ARE IN INCHES
 FINISH: TO BE DETERMINED

PATTERN OPENNESS: 63%

| | |
|----------|----------|
| SCALE | NONE |
| DRAWN | DH |
| DATE | 10-18-06 |
| Q.A. | |
| COMMENTS | |

HERRINGBONE DESIGN

THIS INFORMATION CONTAINED IN THIS DRAWING IS THE SOLE PROPERTY OF STEELCREST CORPORATION. ANY REPRODUCTION IN PART OR AS A WHOLE WITHOUT WRITTEN PERMISSION OF STEELCREST CORPORATION IS PROHIBITED

PATTERN DETAIL MEASUREMENTS

NOTE: MEASUREMENTS ARE APPROXIMATE AND WILL VARY WITH REGISTER SIZE.

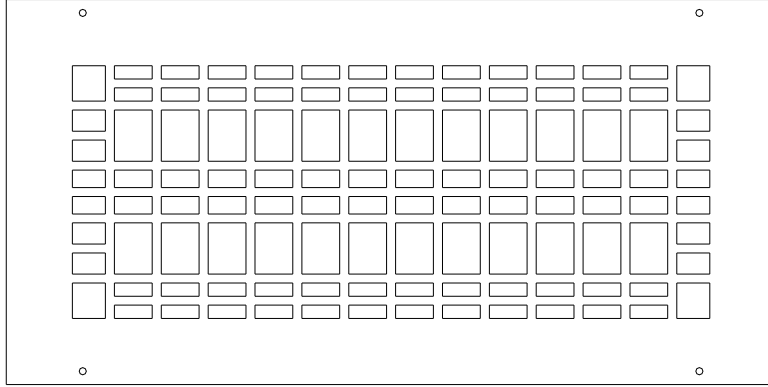
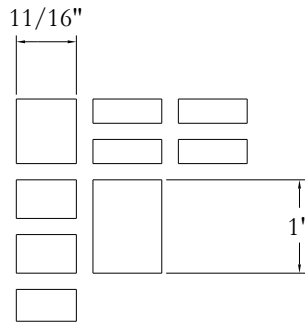

| Air Flow Performance Data | | | | | |
|----------------------------|-----------|----------|-----------|------------|------------|
| Velocity Static Pressure | 250 0.015 | 500 0.03 | 750 0.046 | 1000 0.061 | 1500 0.093 |
| Size | CFM | | | | |
| 6x6 .25 ft ² | 40 | 80 | 120 | 160 | 235 |
| 8x8 .44 ft ² | 70 | 140 | 210 | 280 | 425 |
| 10x10 .69 ft ² | 110 | 220 | 330 | 440 | 660 |
| 12x12 1.0 ft ² | 160 | 320 | 475 | 635 | 955 |
| 14x14 1.36 ft ² | 216 | 431 | 647 | 862 | 1294 |
| 8x6 .33 ft ² | 53 | 106 | 158 | 211 | 317 |
| 10x6 .42 ft ² | 66 | 132 | 198 | 264 | 396 |
| 12x6 .5 ft ² | 79 | 158 | 238 | 317 | 475 |
| 14x6 .58 ft ² | 92 | 185 | 277 | 370 | 554 |
| 16x6 .67 ft ² | 106 | 211 | 317 | 422 | 634 |
| 18x6 .75 ft ² | 119 | 238 | 356 | 475 | 713 |
| 20x6 .83 ft ² | 132 | 264 | 396 | 528 | 792 |
| 10x8 .56 ft ² | 88 | 176 | 264 | 352 | 528 |
| 12x8 .67 ft ² | 106 | 211 | 317 | 422 | 634 |
| 14x8 .78 ft ² | 123 | 246 | 370 | 493 | 739 |
| 8x4 .22 ft ² | 35 | 70 | 106 | 141 | 211 |
| 10x4 .28 ft ² | 44 | 88 | 132 | 176 | 264 |
| 12x4 .33 ft ² | 53 | 106 | 158 | 211 | 317 |



MATERIAL: 11 GAUGE STEEL
 ABOVE DIMENSIONS ARE IN INCHES
 FINISH: TO BE DETERMINED
 PATTERN OPENNESS: 62%

SCALE: NONE
 DRAWN: DH
 DATE: 10-18-06
 Q.A.
 COMMENTS

MISSION DESIGN

THIS INFORMATION CONTAINED IN THIS DRAWING IS THE SOLE PROPERTY OF STEELCREST CORPORATION. ANY REPRODUCTION IN PART OR AS A WHOLE WITHOUT WRITTEN PERMISSION OF STEELCREST CORPORATION IS PROHIBITED

PATTERN DETAIL MEASUREMENTS

NOTE: MEASUREMENTS ARE APPROXIMATE AND WILL VARY WITH REGISTER SIZE.

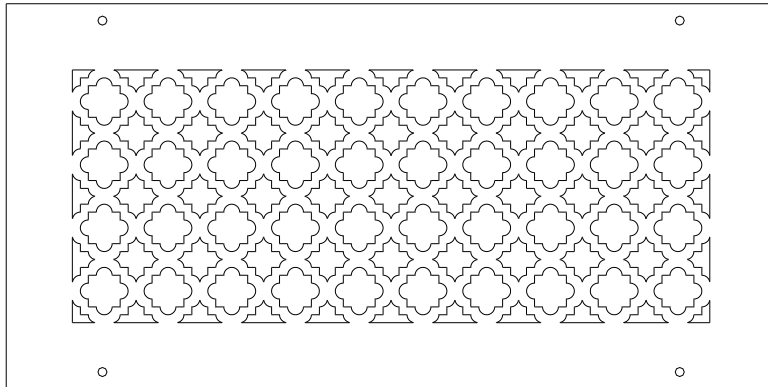
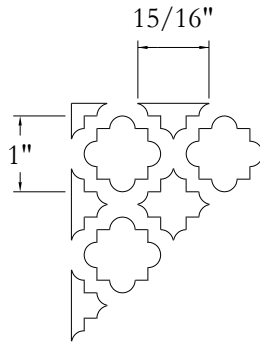

| Air Flow Performance Data | | | | | |
|----------------------------|-----------|-----------|-----------|------------|------------|
| Velocity Static Pressure | 250 0.009 | 500 0.018 | 750 0.027 | 1000 0.036 | 1500 0.055 |
| Size | CFM | | | | |
| 6x6 .25 ft ² | 45 | 92 | 135 | 185 | 275 |
| 8x8 .44 ft ² | 80 | 160 | 240 | 320 | 480 |
| 10x10 .69 ft ² | 125 | 250 | 375 | 500 | 750 |
| 12x12 1.0 ft ² | 180 | 360 | 540 | 720 | 1100 |
| 14x14 1.36 ft ² | 245 | 490 | 735 | 980 | 1470 |
| 8x6 .33 ft ² | 60 | 120 | 180 | 240 | 360 |
| 10x6 .42 ft ² | 75 | 150 | 225 | 300 | 450 |
| 12x6 .5 ft ² | 90 | 180 | 270 | 360 | 540 |
| 14x6 .58 ft ² | 105 | 210 | 315 | 420 | 630 |
| 16x6 .67 ft ² | 120 | 240 | 360 | 480 | 720 |
| 18x6 .75 ft ² | 135 | 270 | 405 | 540 | 810 |
| 20x6 .83 ft ² | 150 | 300 | 450 | 600 | 900 |
| 10x8 .56 ft ² | 100 | 200 | 300 | 400 | 600 |
| 12x8 .67 ft ² | 120 | 240 | 360 | 480 | 720 |
| 14x8 .78 ft ² | 140 | 280 | 420 | 560 | 840 |
| 8x4 .22 ft ² | 40 | 80 | 120 | 160 | 240 |
| 10x4 .28 ft ² | 50 | 100 | 150 | 200 | 300 |
| 12x4 .33 ft ² | 60 | 120 | 180 | 240 | 360 |



MATERIAL: 11 GAUGE STEEL
 ABOVE DIMENSIONS ARE IN INCHES
 FINISH: TO BE DETERMINED
 PATTERN OPENNESS: 65%

SCALE: NONE
 DRAWN: DH
 DATE: 10-18-06
 Q.A.
 COMMENTS

NEW CLASSIC DESIGN

THIS INFORMATION CONTAINED IN THIS DRAWING IS THE SOLE PROPERTY OF STEELCREST CORPORATION. ANY REPRODUCTION IN PART OR AS A WHOLE WITHOUT WRITTEN PERMISSION OF STEELCREST CORPORATION IS PROHIBITED

PATTERN DETAIL MEASUREMENTS

NOTE: MEASUREMENTS ARE APPROXIMATE AND WILL VARY WITH REGISTER SIZE.

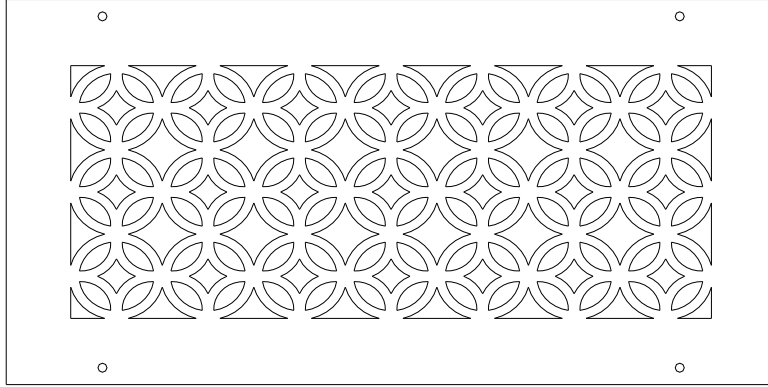
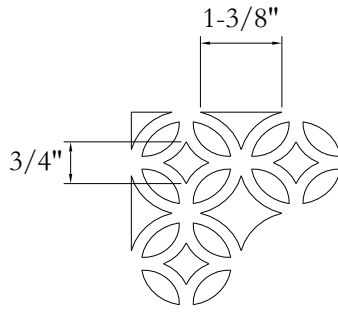

| Air Flow Performance Data | | | | | |
|----------------------------|-------|-------|-------|-------|-------|
| Velocity Static Pressure | 250 | 500 | 750 | 1000 | 1500 |
| | 0.017 | 0.034 | 0.052 | 0.069 | 0.104 |
| Size | CFM | | | | |
| 6x6 .25 ft ² | 32 | 72 | 100 | 135 | 210 |
| 8x8 .44 ft ² | 62 | 122 | 185 | 245 | 370 |
| 10x10 .69 ft ² | 96 | 195 | 290 | 380 | 580 |
| 12x12 1.0 ft ² | 138 | 282 | 422 | 555 | 840 |
| 14x14 1.36 ft ² | 190 | 385 | 565 | 750 | 1120 |
| 8x6 .33 ft ² | 43 | 93 | 138 | 185 | 279 |
| 10x6 .42 ft ² | 57 | 115 | 170 | 230 | 345 |
| 12x6 .5 ft ² | 68 | 140 | 202 | 272 | 410 |
| 14x6 .58 ft ² | 79 | 165 | 237 | 325 | 480 |
| 16x6 .67 ft ² | 91 | 188 | 270 | 362 | 550 |
| 18x6 .75 ft ² | 103 | 212 | 300 | 410 | 625 |
| 20x6 .83 ft ² | 115 | 235 | 335 | 460 | 685 |
| 10x8 .56 ft ² | 75 | 156 | 320 | 306 | 465 |
| 12x8 .67 ft ² | 91 | 187 | 270 | 360 | 550 |
| 14x8 .78 ft ² | 105 | 220 | 320 | 435 | 650 |
| 8x4 .22 ft ² | 29 | 60 | 90 | 121 | 185 |
| 10x4 .28 ft ² | 37 | 77 | 113 | 152 | 230 |
| 12x4 .33 ft ² | 43 | 91 | 135 | 184 | 275 |



MATERIAL: 11 GAUGE STEEL
 ABOVE DIMENSIONS ARE IN INCHES
 FINISH: TO BE DETERMINED
 PATTERN OPENNESS: 47%

SCALE: NONE
 DRAWN: DH
 DATE: 10-18-06
 Q.A.
 COMMENTS

OMNI DESIGN

THIS INFORMATION CONTAINED IN THIS DRAWING IS THE SOLE PROPERTY OF STEELCREST CORPORATION. ANY REPRODUCTION IN PART OR AS A WHOLE WITHOUT WRITTEN PERMISSION OF STEELCREST CORPORATION IS PROHIBITED

PATTERN DETAIL MEASUREMENTS

NOTE: MEASUREMENTS ARE APPROXIMATE AND WILL VARY WITH REGISTER SIZE.

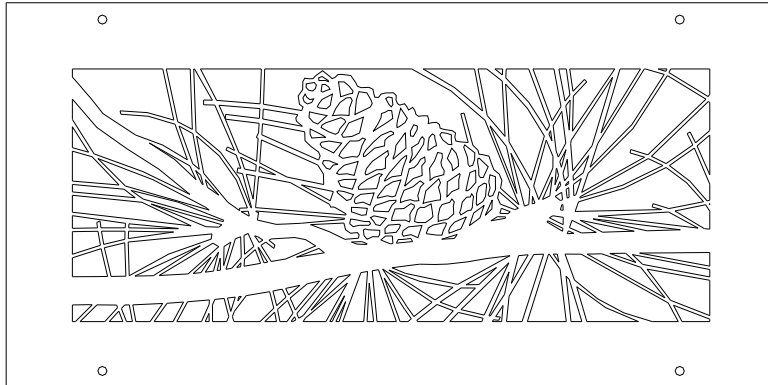
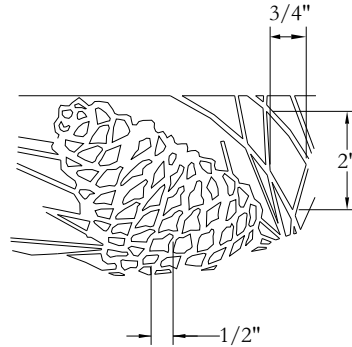

| Air Flow Performance Data | | | | | |
|----------------------------|-------|-------|--------|-------|-------|
| Velocity Static Pressure | 250 | 500 | 750 | 1000 | 1500 |
| | 0.005 | 0.011 | 0.0175 | 0.023 | 0.035 |
| Size | CFM | | | | |
| 6x6 .25 ft ² | 42 | 85 | 125 | 170 | 255 |
| 8x8 .44 ft ² | 75 | 150 | 225 | 300 | 450 |
| 10x10 .69 ft ² | 115 | 235 | 350 | 465 | 700 |
| 12x12 1.0 ft ² | 167 | 335 | 500 | 680 | 1020 |
| 14x14 1.36 ft ² | 225 | 461 | 686 | 911 | 1372 |
| 8x6 .33 ft ² | 55 | 113 | 168 | 223 | 336 |
| 10x6 .42 ft ² | 69 | 141 | 210 | 279 | 420 |
| 12x6 .5 ft ² | 83 | 169 | 252 | 335 | 504 |
| 14x6 .58 ft ² | 97 | 197 | 294 | 391 | 588 |
| 16x6 .67 ft ² | 110 | 226 | 336 | 446 | 672 |
| 18x6 .75 ft ² | 124 | 254 | 378 | 502 | 756 |
| 20x6 .83 ft ² | 138 | 282 | 420 | 558 | 840 |
| 10x8 .56 ft ² | 92 | 188 | 280 | 372 | 560 |
| 12x8 .67 ft ² | 110 | 226 | 336 | 446 | 672 |
| 14x8 .78 ft ² | 129 | 263 | 392 | 521 | 784 |
| 8x4 .22 ft ² | 37 | 75 | 112 | 149 | 224 |
| 10x4 .28 ft ² | 46 | 94 | 140 | 186 | 280 |
| 12x4 .33 ft ² | 55 | 113 | 168 | 223 | 336 |



MATERIAL: 11 GAUGE STEEL
 ABOVE DIMENSIONS ARE IN INCHES
 FINISH: TO BE DETERMINED
 PATTERN OPENNESS: 63%

SCALE: NONE
 DRAWN: DH
 DATE: 10-18-06
 Q.A.
 COMMENTS

PINECONE DESIGN

THIS INFORMATION CONTAINED IN THIS DRAWING IS THE SOLE PROPERTY OF STEELCREST CORPORATION. ANY REPRODUCTION IN PART OR AS A WHOLE WITHOUT WRITTEN PERMISSION OF STEELCREST CORPORATION IS PROHIBITED

PATTERN DETAIL MEASUREMENTS

NOTE: MEASUREMENTS ARE APPROXIMATE AND WILL VARY WITH REGISTER SIZE.

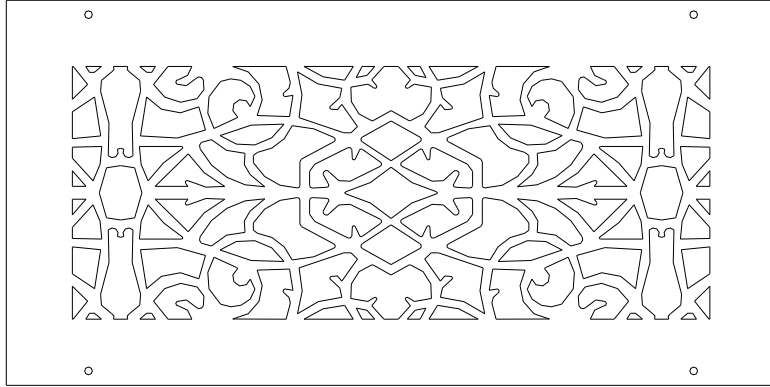
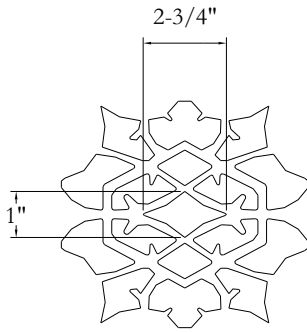

| Air Flow Performance Data | | | | | |
|-------------------------------|--------------|--------------|---------------|---------------|---------------|
| Velocity Static Pressure | 250 0.005 | 500 0.011 | 750 0.0175 | 1000 0.023 | 1500 0.035 |
| Size | CFM | | | | |
| 6x6 .25 ft ² | 42 | 85 | 125 | 170 | 255 |
| 8x8 .44 ft ² | 75 | 150 | 225 | 300 | 450 |
| 10x10 .69 ft ² | 115 | 235 | 350 | 465 | 700 |
| 12x12 1.0 ft ² | 167 | 335 | 500 | 680 | 1020 |
| 14x14 1.36 ft ² | 225 | 461 | 686 | 911 | 1372 |
| 8x6 .33 ft ² | 55 | 113 | 168 | 223 | 336 |
| 10x6 .42 ft ² | 69 | 141 | 210 | 279 | 420 |
| 12x6 .5 ft ² | 83 | 169 | 252 | 335 | 504 |
| 14x6 .58 ft ² | 97 | 197 | 294 | 391 | 588 |
| 16x6 .67 ft ² | 110 | 226 | 336 | 446 | 672 |
| 18x6 .75 ft ² | 124 | 254 | 378 | 502 | 756 |
| 20x6 .83 ft ² | 138 | 282 | 420 | 558 | 840 |
| 10x8 .56 ft ² | 92 | 188 | 280 | 372 | 560 |
| 12x8 .67 ft ² | 110 | 226 | 336 | 446 | 672 |
| 14x8 .78 ft ² | 129 | 263 | 392 | 521 | 784 |
| 8x4 .22 ft ² | 37 | 75 | 112 | 149 | 224 |
| 10x4 .28 ft ² | 46 | 94 | 140 | 186 | 280 |
| 12x4 .33 ft ² | 55 | 113 | 168 | 223 | 336 |



MATERIAL: 11 GAUGE STEEL
 ABOVE DIMENSIONS ARE IN INCHES
 FINISH: TO BE DETERMINED
 PATTERN OPENNESS: 63%

| | |
|----------|----------|
| SCALE | NONE |
| DRAWN | DH |
| DATE | 10-18-06 |
| Q.A. | |
| COMMENTS | |

PRESIDENTIAL DESIGN

THIS INFORMATION CONTAINED IN THIS DRAWING IS THE SOLE PROPERTY OF STEELCREST CORPORATION. ANY REPRODUCTION IN PART OR AS A WHOLE WITHOUT WRITTEN PERMISSION OF STEELCREST CORPORATION IS PROHIBITED

PATTERN DETAIL MEASUREMENTS

NOTE: MEASUREMENTS ARE APPROXIMATE AND WILL VARY WITH REGISTER SIZE.

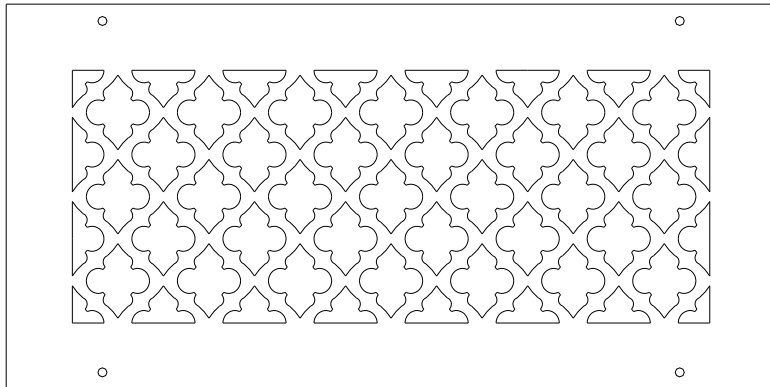
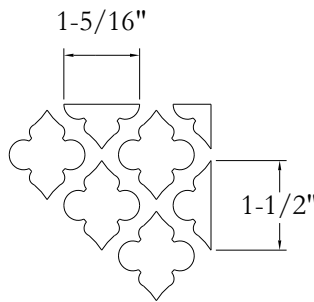

| Air Flow Performance Data | | | | | |
|-------------------------------|--------------|--------------|--------------|---------------|---------------|
| Velocity Static Pressure | 250 0.009 | 500 0.018 | 750 0.027 | 1000 0.036 | 1500 0.055 |
| Size | CFM | | | | |
| 6x6 .25 ft ² | 45 | 92 | 135 | 185 | 275 |
| 8x8 .44 ft ² | 80 | 160 | 240 | 320 | 480 |
| 10x10 .69 ft ² | 125 | 250 | 375 | 500 | 750 |
| 12x12 1.0 ft ² | 180 | 360 | 540 | 720 | 1100 |
| 14x14 1.36 ft ² | 245 | 490 | 735 | 980 | 1470 |
| 8x6 .33 ft ² | 60 | 120 | 180 | 240 | 360 |
| 10x6 .42 ft ² | 75 | 150 | 225 | 300 | 450 |
| 12x6 .5 ft ² | 90 | 180 | 270 | 360 | 540 |
| 14x6 .58 ft ² | 105 | 210 | 315 | 420 | 630 |
| 16x6 .67 ft ² | 120 | 240 | 360 | 480 | 720 |
| 18x6 .75 ft ² | 135 | 270 | 405 | 540 | 810 |
| 20x6 .83 ft ² | 150 | 300 | 450 | 600 | 900 |
| 10x8 .56 ft ² | 100 | 200 | 300 | 400 | 600 |
| 12x8 .67 ft ² | 120 | 240 | 360 | 480 | 720 |
| 14x8 .78 ft ² | 140 | 280 | 420 | 560 | 840 |
| 8x4 .22 ft ² | 40 | 80 | 120 | 160 | 240 |
| 10x4 .28 ft ² | 50 | 100 | 150 | 200 | 300 |
| 12x4 .33 ft ² | 60 | 120 | 180 | 240 | 360 |



MATERIAL: 11 GAUGE STEEL
 ABOVE DIMENSIONS ARE IN INCHES
 FINISH: TO BE DETERMINED
 PATTERN OPENNESS: 65%

| | |
|----------|----------|
| SCALE | NONE |
| DRAWN | DH |
| DATE | 10-18-06 |
| Q.A. | |
| COMMENTS | |

REGENCY DESIGN

THIS INFORMATION CONTAINED IN THIS DRAWING IS THE SOLE PROPERTY OF STEELCREST CORPORATION. ANY REPRODUCTION IN PART OR AS A WHOLE WITHOUT WRITTEN PERMISSION OF STEELCREST CORPORATION IS PROHIBITED

PATTERN DETAIL MEASUREMENTS

NOTE: MEASUREMENTS ARE APPROXIMATE AND WILL VARY WITH REGISTER SIZE.

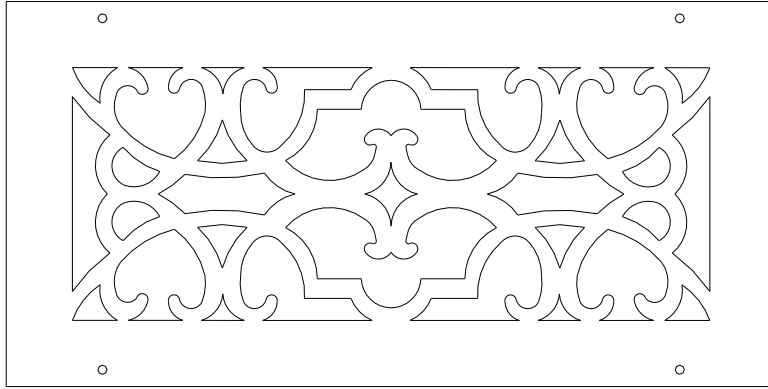
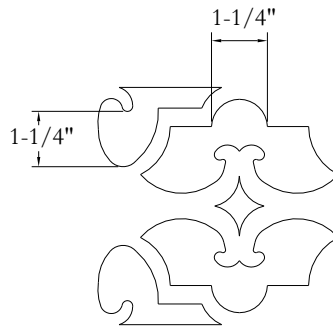

| Air Flow Performance Data | | | | | |
|----------------------------|----------|-----------|-----------|------------|------------|
| Velocity Static Pressure | 250 0.02 | 500 0.042 | 750 0.063 | 1000 0.084 | 1500 0.126 |
| Size | CFM | | | | |
| 6x6 .25 ft ² | 39 | 77 | 118 | 157 | 232 |
| 8x8 .44 ft ² | 69 | 137 | 207 | 275 | 418 |
| 10x10 .69 ft ² | 108 | 215 | 322 | 432 | 650 |
| 12x12 1.0 ft ² | 157 | 310 | 467 | 620 | 942 |
| 14x14 1.36 ft ² | 213 | 420 | 635 | 845 | 1261 |
| 8x6 .33 ft ² | 52 | 104 | 155 | 207 | 312 |
| 10x6 .42 ft ² | 66 | 130 | 196 | 260 | 388 |
| 12x6 .5 ft ² | 78 | 156 | 235 | 312 | 463 |
| 14x6 .58 ft ² | 91 | 181 | 272 | 365 | 545 |
| 16x6 .67 ft ² | 105 | 207 | 312 | 416 | 620 |
| 18x6 .75 ft ² | 118 | 232 | 350 | 465 | 697 |
| 20x6 .83 ft ² | 130 | 260 | 390 | 515 | 781 |
| 10x8 .56 ft ² | 87 | 172 | 260 | 346 | 520 |
| 12x8 .67 ft ² | 104 | 205 | 312 | 418 | 621 |
| 14x8 .78 ft ² | 122 | 240 | 365 | 482 | 722 |
| 8x4 .22 ft ² | 35 | 69 | 104 | 138 | 207 |
| 10x4 .28 ft ² | 44 | 87 | 130 | 171 | 260 |
| 12x4 .33 ft ² | 52 | 104 | 155 | 205 | 312 |



MATERIAL: 11 GAUGE STEEL
 ABOVE DIMENSIONS ARE IN INCHES
 FINISH: TO BE DETERMINED

PATTERN OPENNESS: 61%

| | |
|----------|----------|
| SCALE | NONE |
| DRAWN | DH |
| DATE | 10-18-06 |
| Q.A. | |
| COMMENTS | |

RENAISSANCE DESIGN

THIS INFORMATION CONTAINED IN THIS DRAWING IS THE SOLE PROPERTY OF STEELCREST CORPORATION. ANY REPRODUCTION IN PART OR AS A WHOLE WITHOUT WRITTEN PERMISSION OF STEELCREST CORPORATION IS PROHIBITED

PATTERN DETAIL MEASUREMENTS

NOTE: MEASUREMENTS ARE APPROXIMATE AND WILL VARY WITH REGISTER SIZE.

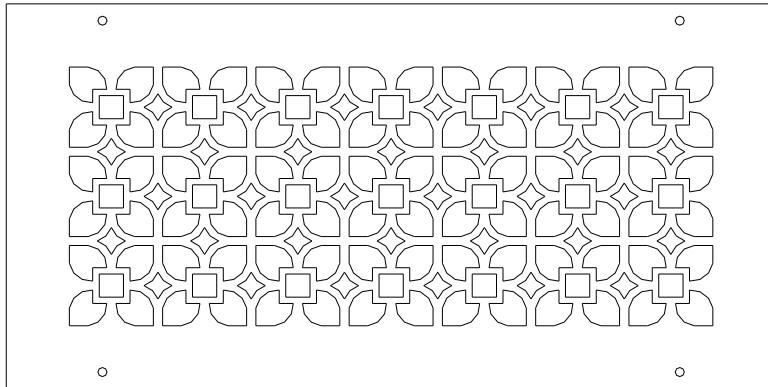
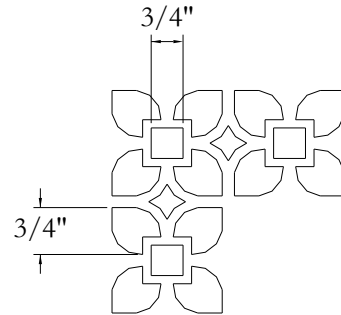

| Air Flow Performance Data | | | | | |
|----------------------------|-----------|-----------|------------|------------|------------|
| Velocity Static Pressure | 250 0.005 | 500 0.011 | 750 0.0175 | 1000 0.023 | 1500 0.035 |
| Size | CFM | | | | |
| 6x6 .25 ft ² | 42 | 85 | 125 | 170 | 255 |
| 8x8 .44 ft ² | 75 | 150 | 225 | 300 | 450 |
| 10x10 .69 ft ² | 115 | 235 | 350 | 465 | 700 |
| 12x12 1.0 ft ² | 167 | 335 | 500 | 680 | 1020 |
| 14x14 1.36 ft ² | 225 | 461 | 686 | 911 | 1372 |
| 8x6 .33 ft ² | 55 | 113 | 168 | 223 | 336 |
| 10x6 .42 ft ² | 69 | 141 | 210 | 279 | 420 |
| 12x6 .5 ft ² | 83 | 169 | 252 | 335 | 504 |
| 14x6 .58 ft ² | 97 | 197 | 294 | 391 | 588 |
| 16x6 .67 ft ² | 110 | 226 | 336 | 446 | 672 |
| 18x6 .75 ft ² | 124 | 254 | 378 | 502 | 756 |
| 20x6 .83 ft ² | 138 | 282 | 420 | 558 | 840 |
| 10x8 .56 ft ² | 92 | 188 | 280 | 372 | 560 |
| 12x8 .67 ft ² | 110 | 226 | 336 | 446 | 672 |
| 14x8 .78 ft ² | 129 | 263 | 392 | 521 | 784 |
| 8x4 .22 ft ² | 37 | 75 | 112 | 149 | 224 |
| 10x4 .28 ft ² | 46 | 94 | 140 | 186 | 280 |
| 12x4 .33 ft ² | 55 | 113 | 168 | 223 | 336 |



MATERIAL: 11 GAUGE STEEL
 ABOVE DIMENSIONS ARE IN INCHES
 FINISH: TO BE DETERMINED

PATTERN OPENNESS: 63%

| | |
|----------|----------|
| SCALE | NONE |
| DRAWN | DH |
| DATE | 10-18-06 |
| Q.A. | |
| COMMENTS | |

ROYAL PALM DESIGN

THIS INFORMATION CONTAINED IN THIS DRAWING IS THE SOLE PROPERTY OF STEELCREST CORPORATION. ANY REPRODUCTION IN PART OR AS A WHOLE WITHOUT WRITTEN PERMISSION OF STEELCREST CORPORATION IS PROHIBITED

PATTERN DETAIL MEASUREMENTS

NOTE: MEASUREMENTS ARE APPROXIMATE AND WILL VARY WITH REGISTER SIZE.

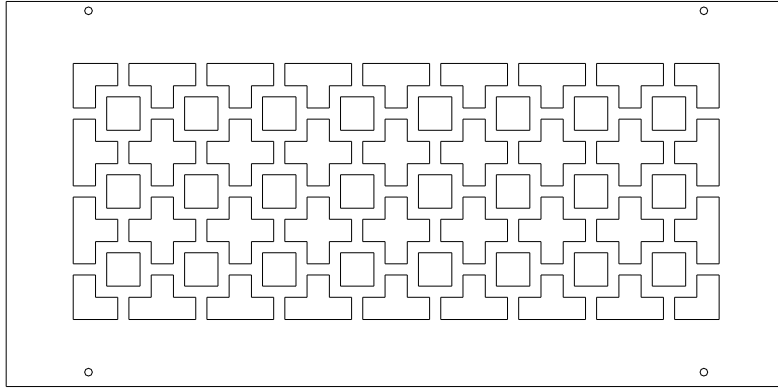
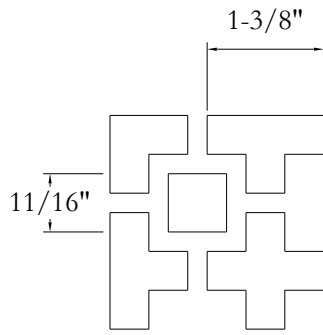

| Air Flow Performance Data | | | | | |
|----------------------------|-----------|-----------|------------|------------|------------|
| Velocity Static Pressure | 250 0.005 | 500 0.011 | 750 0.0175 | 1000 0.023 | 1500 0.035 |
| Size | CFM | | | | |
| 6x6 .25 ft ² | 43 | 87 | 127 | 175 | 262 |
| 8x8 .44 ft ² | 77 | 150 | 225 | 300 | 460 |
| 10x10 .69 ft ² | 120 | 235 | 350 | 465 | 720 |
| 12x12 1.0 ft ² | 171 | 335 | 512 | 680 | 1062 |
| 14x14 1.36 ft ² | 232 | 461 | 686 | 911 | 1398 |
| 8x6 .53 ft ² | 57 | 113 | 168 | 223 | 348 |
| 10x6 .72 ft ² | 72 | 141 | 212 | 279 | 435 |
| 12x6 .87 ft ² | 87 | 169 | 252 | 350 | 530 |
| 14x6 1.01 ft ² | 101 | 205 | 294 | 391 | 605 |
| 16x6 1.15 ft ² | 115 | 226 | 336 | 452 | 703 |
| 18x6 1.31 ft ² | 131 | 260 | 378 | 502 | 785 |
| 20x6 1.45 ft ² | 145 | 282 | 420 | 558 | 872 |
| 10x8 .56 ft ² | 96 | 188 | 280 | 372 | 580 |
| 12x8 .67 ft ² | 115 | 232 | 342 | 446 | 703 |
| 14x8 .78 ft ² | 135 | 263 | 392 | 521 | 805 |
| 8x4 .22 ft ² | 38 | 75 | 112 | 149 | 234 |
| 10x4 .28 ft ² | 48 | 94 | 143 | 186 | 290 |
| 12x4 .33 ft ² | 57 | 113 | 168 | 223 | 348 |



MATERIAL: 11 GAUGE STEEL
 ABOVE DIMENSIONS ARE IN INCHES
 FINISH: TO BE DETERMINED

PATTERN OPENNESS: 64%

| | |
|----------|----------|
| SCALE | NONE |
| DRAWN | DH |
| DATE | 10-18-06 |
| Q.A. | |
| COMMENTS | |

SANTA FE DESIGN

THIS INFORMATION CONTAINED IN THIS DRAWING IS THE SOLE PROPERTY OF STEELCREST CORPORATION. ANY REPRODUCTION IN PART OR AS A WHOLE WITHOUT WRITTEN PERMISSION OF STEELCREST CORPORATION IS PROHIBITED

PATTERN DETAIL MEASUREMENTS

NOTE: MEASUREMENTS ARE APPROXIMATE AND WILL VARY WITH REGISTER SIZE.

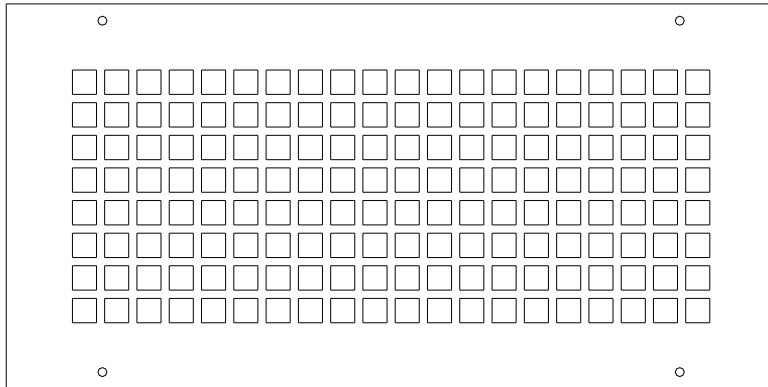
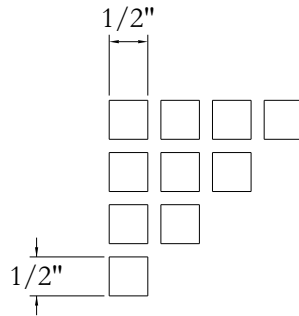

| Air Flow Performance Data | | | | | |
|----------------------------|----------|-----------|-----------|------------|------------|
| Velocity Static Pressure | 250 0.02 | 500 0.042 | 750 0.063 | 1000 0.084 | 1500 0.126 |
| Size | CFM | | | | |
| 6x6 .25 ft ² | 39 | 77 | 118 | 157 | 232 |
| 8x8 .44 ft ² | 69 | 137 | 207 | 275 | 418 |
| 10x10 .69 ft ² | 108 | 215 | 322 | 432 | 650 |
| 12x12 1.0 ft ² | 157 | 310 | 467 | 620 | 942 |
| 14x14 1.36 ft ² | 213 | 420 | 635 | 845 | 1261 |
| 8x6 .33 ft ² | 52 | 104 | 155 | 207 | 312 |
| 10x6 .42 ft ² | 66 | 130 | 196 | 260 | 388 |
| 12x6 .5 ft ² | 78 | 156 | 235 | 312 | 463 |
| 14x6 .58 ft ² | 91 | 181 | 272 | 365 | 545 |
| 16x6 .67 ft ² | 105 | 207 | 312 | 416 | 620 |
| 18x6 .75 ft ² | 118 | 232 | 350 | 465 | 697 |
| 20x6 .83 ft ² | 130 | 260 | 390 | 515 | 781 |
| 10x8 .56 ft ² | 87 | 172 | 260 | 346 | 520 |
| 12x8 .67 ft ² | 104 | 205 | 312 | 418 | 621 |
| 14x8 .78 ft ² | 122 | 240 | 365 | 482 | 722 |
| 8x4 .22 ft ² | 35 | 69 | 104 | 138 | 207 |
| 10x4 .28 ft ² | 44 | 87 | 130 | 171 | 260 |
| 12x4 .33 ft ² | 52 | 104 | 155 | 205 | 312 |



MATERIAL: 11 GAUGE STEEL
 ABOVE DIMENSIONS ARE IN INCHES
 FINISH: TO BE DETERMINED

PATTERN OPENNESS: 61%

| | |
|----------|----------|
| SCALE | NONE |
| DRAWN | DH |
| DATE | 10-18-06 |
| Q.A. | |
| COMMENTS | |

SQUARE DESIGN

THIS INFORMATION CONTAINED IN THIS DRAWING IS THE SOLE PROPERTY OF STEELCREST CORPORATION. ANY REPRODUCTION IN PART OR AS A WHOLE WITHOUT WRITTEN PERMISSION OF STEELCREST CORPORATION IS PROHIBITED

PATTERN DETAIL MEASUREMENTS

NOTE: MEASUREMENTS ARE APPROXIMATE AND WILL VARY WITH REGISTER SIZE.

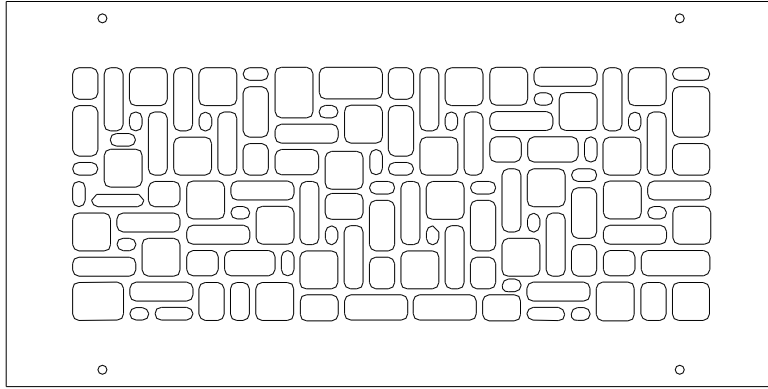
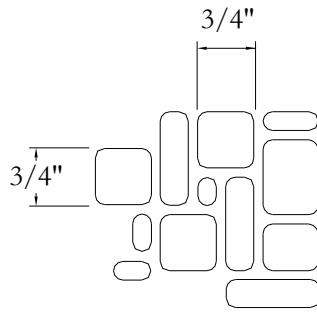

| Air Flow Performance Data | | | | | |
|-------------------------------|--------------|--------------|--------------|---------------|---------------|
| Velocity Static Pressure | 250 0.009 | 500 0.018 | 750 0.027 | 1000 0.036 | 1500 0.055 |
| Size | CFM | | | | |
| 6x6 .25 ft ² | 47 | 97 | 141 | 205 | 311 |
| 8x8 .44 ft ² | 85 | 172 | 255 | 362 | 502 |
| 10x10 .69 ft ² | 130 | 265 | 390 | 544 | 790 |
| 12x12 1.0 ft ² | 187 | 380 | 561 | 740 | 1195 |
| 14x14 1.36 ft ² | 252 | 512 | 742 | 1005 | 1510 |
| 8x6 .33 ft ² | 65 | 131 | 195 | 257 | 382 |
| 10x6 .42 ft ² | 82 | 162 | 232 | 332 | 470 |
| 12x6 .5 ft ² | 97 | 195 | 270 | 360 | 540 |
| 14x6 .58 ft ² | 112 | 218 | 315 | 431 | 655 |
| 16x6 .67 ft ² | 131 | 253 | 374 | 515 | 787 |
| 18x6 .75 ft ² | 147 | 285 | 405 | 540 | 810 |
| 20x6 .83 ft ² | 162 | 318 | 462 | 620 | 932 |
| 10x8 .56 ft ² | 108 | 216 | 332 | 447 | 661 |
| 12x8 .67 ft ² | 131 | 253 | 374 | 500 | 762 |
| 14x8 .78 ft ² | 153 | 292 | 445 | 590 | 865 |
| 8x4 .22 ft ² | 43 | 95 | 120 | 160 | 240 |
| 10x4 .28 ft ² | 55 | 112 | 171 | 221 | 334 |
| 12x4 .33 ft ² | 65 | 131 | 195 | 257 | 382 |



MATERIAL: 11 GAUGE STEEL
 ABOVE DIMENSIONS ARE IN INCHES
 FINISH: TO BE DETERMINED

PATTERN OPENNESS: 67%

SCALE: NONE
 DRAWN: DH
 DATE: 10-18-06
 Q.A.
 COMMENTS

STONEWALL DESIGN

THIS INFORMATION CONTAINED IN THIS DRAWING IS THE SOLE PROPERTY OF STEELCREST CORPORATION. ANY REPRODUCTION IN PART OR AS A WHOLE WITHOUT WRITTEN PERMISSION OF STEELCREST CORPORATION IS PROHIBITED

PATTERN DETAIL MEASUREMENTS

NOTE: MEASUREMENTS ARE APPROXIMATE AND WILL VARY WITH REGISTER SIZE.

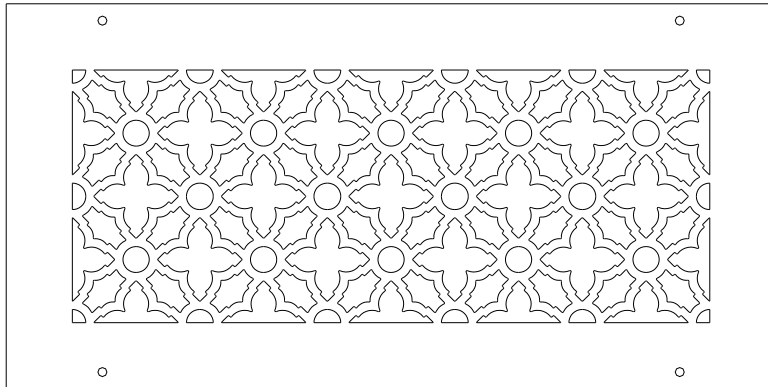
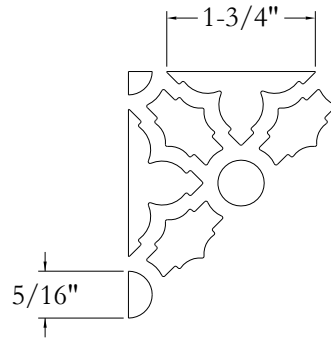

| Air Flow Performance Data | | | | | |
|-------------------------------|--------------|--------------|---------------|---------------|---------------|
| Velocity Static Pressure | 250 0.005 | 500 0.011 | 750 0.0175 | 1000 0.023 | 1500 0.035 |
| Size | CFM | | | | |
| 6x6 .25 ft ² | 42 | 85 | 125 | 170 | 255 |
| 8x8 .44 ft ² | 75 | 150 | 225 | 300 | 450 |
| 10x10 .69 ft ² | 115 | 235 | 350 | 465 | 700 |
| 12x12 1.0 ft ² | 167 | 335 | 500 | 680 | 1020 |
| 14x14 1.36 ft ² | 225 | 461 | 686 | 911 | 1372 |
| 8x6 .33 ft ² | 55 | 113 | 168 | 223 | 336 |
| 10x6 .42 ft ² | 69 | 141 | 210 | 279 | 420 |
| 12x6 .5 ft ² | 83 | 169 | 252 | 335 | 504 |
| 14x6 .58 ft ² | 97 | 197 | 294 | 391 | 588 |
| 16x6 .67 ft ² | 110 | 226 | 336 | 446 | 672 |
| 18x6 .75 ft ² | 124 | 254 | 378 | 502 | 756 |
| 20x6 .83 ft ² | 138 | 282 | 420 | 558 | 840 |
| 10x8 .56 ft ² | 92 | 188 | 280 | 372 | 560 |
| 12x8 .67 ft ² | 110 | 226 | 336 | 446 | 672 |
| 14x8 .78 ft ² | 129 | 263 | 392 | 521 | 784 |
| 8x4 .22 ft ² | 37 | 75 | 112 | 149 | 224 |
| 10x4 .28 ft ² | 46 | 94 | 140 | 186 | 280 |
| 12x4 .33 ft ² | 55 | 113 | 168 | 223 | 336 |



MATERIAL: 11 GAUGE STEEL
 ABOVE DIMENSIONS ARE IN INCHES
 FINISH: TO BE DETERMINED

PATTERN OPENNESS: 63%

SCALE: NONE
 DRAWN: DH
 DATE: 10-18-06
 Q.A.
 COMMENTS

TRADITIONAL DESIGN

THIS INFORMATION CONTAINED IN THIS DRAWING IS THE SOLE PROPERTY OF STEELCREST CORPORATION. ANY REPRODUCTION IN PART OR AS A WHOLE WITHOUT WRITTEN PERMISSION OF STEELCREST CORPORATION IS PROHIBITED

PATTERN DETAIL MEASUREMENTS

NOTE: MEASUREMENTS ARE APPROXIMATE AND WILL VARY WITH REGISTER SIZE.

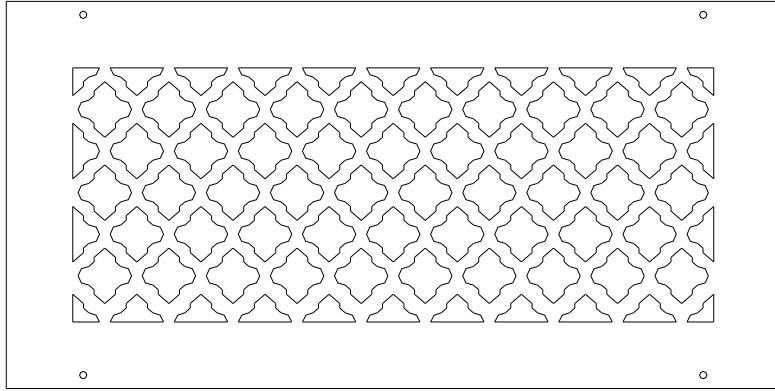
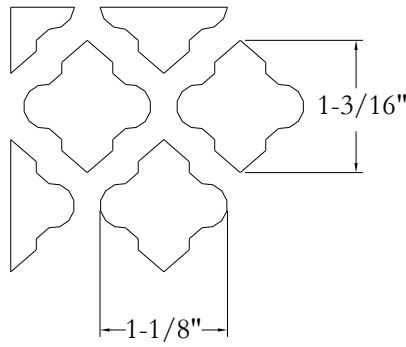

| Air Flow Performance Data | | | | | |
|-------------------------------|--------------|--------------|--------------|---------------|---------------|
| Velocity Static Pressure | 250 0.009 | 500 0.018 | 750 0.027 | 1000 0.036 | 1500 0.055 |
| Size | CFM | | | | |
| 6x6 .25 ft ² | 45 | 92 | 135 | 185 | 275 |
| 8x8 .44 ft ² | 80 | 160 | 240 | 320 | 480 |
| 10x10 .69 ft ² | 125 | 250 | 375 | 500 | 750 |
| 12x12 1.0 ft ² | 180 | 360 | 540 | 720 | 1100 |
| 14x14 1.36 ft ² | 245 | 490 | 735 | 980 | 1470 |
| 8x6 .33 ft ² | 60 | 120 | 180 | 240 | 360 |
| 10x6 .42 ft ² | 75 | 150 | 225 | 300 | 450 |
| 12x6 .5 ft ² | 90 | 180 | 270 | 360 | 540 |
| 14x6 .58 ft ² | 105 | 210 | 315 | 420 | 630 |
| 16x6 .67 ft ² | 120 | 240 | 360 | 480 | 720 |
| 18x6 .75 ft ² | 135 | 270 | 405 | 540 | 810 |
| 20x6 .83 ft ² | 150 | 300 | 450 | 600 | 900 |
| 10x8 .56 ft ² | 100 | 200 | 300 | 400 | 600 |
| 12x8 .67 ft ² | 120 | 240 | 360 | 480 | 720 |
| 14x8 .78 ft ² | 140 | 280 | 420 | 560 | 840 |
| 8x4 .22 ft ² | 40 | 80 | 120 | 160 | 240 |
| 10x4 .28 ft ² | 50 | 100 | 150 | 200 | 300 |
| 12x4 .33 ft ² | 60 | 120 | 180 | 240 | 360 |



MATERIAL: 11 GAUGE STEEL
 ABOVE DIMENSIONS ARE IN INCHES
 FINISH: TO BE DETERMINED
 PATTERN OPENNESS: 65%

SCALE: NONE
 DRAWN: DH
 DATE: 10-18-06
 Q.A.
 COMMENTS

TUSCAN DESIGN

THIS INFORMATION CONTAINED IN THIS DRAWING IS THE SOLE PROPERTY OF STEELCREST CORPORATION. ANY REPRODUCTION IN PART OR AS A WHOLE WITHOUT WRITTEN PERMISSION OF STEELCREST CORPORATION IS PROHIBITED

PATTERN DETAIL MEASUREMENTS

NOTE: MEASUREMENTS ARE APPROXIMATE AND WILL VARY WITH REGISTER SIZE.

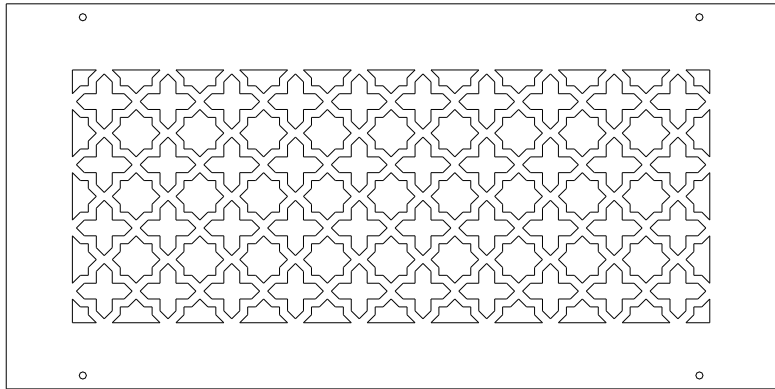
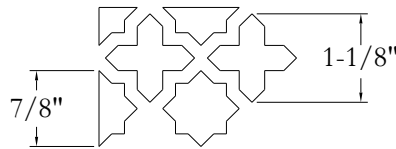

| Air Flow Performance Data | | | | | |
|-------------------------------|--------------|--------------|---------------|---------------|---------------|
| Velocity Static Pressure | 250 0.005 | 500 0.011 | 750 0.0175 | 1000 0.023 | 1500 0.035 |
| Size | CFM | | | | |
| 6x6 .25 ft ² | 42 | 85 | 125 | 170 | 255 |
| 8x8 .44 ft ² | 75 | 150 | 225 | 300 | 450 |
| 10x10 .69 ft ² | 115 | 235 | 350 | 465 | 700 |
| 12x12 1.0 ft ² | 167 | 335 | 500 | 680 | 1020 |
| 14x14 1.36 ft ² | 225 | 461 | 686 | 911 | 1372 |
| 8x6 .33 ft ² | 55 | 113 | 168 | 223 | 336 |
| 10x6 .42 ft ² | 69 | 141 | 210 | 279 | 420 |
| 12x6 .5 ft ² | 83 | 169 | 252 | 335 | 504 |
| 14x6 .58 ft ² | 97 | 197 | 294 | 391 | 588 |
| 16x6 .67 ft ² | 110 | 226 | 336 | 446 | 672 |
| 18x6 .75 ft ² | 124 | 254 | 378 | 502 | 756 |
| 20x6 .83 ft ² | 138 | 282 | 420 | 558 | 840 |
| 10x8 .56 ft ² | 92 | 188 | 280 | 372 | 560 |
| 12x8 .67 ft ² | 110 | 226 | 336 | 446 | 672 |
| 14x8 .78 ft ² | 129 | 263 | 392 | 521 | 784 |
| 8x4 .22 ft ² | 37 | 75 | 112 | 149 | 224 |
| 10x4 .28 ft ² | 46 | 94 | 140 | 186 | 280 |
| 12x4 .33 ft ² | 55 | 113 | 168 | 223 | 336 |



MATERIAL: 11 GAUGE STEEL
 ABOVE DIMENSIONS ARE IN INCHES
 FINISH: TO BE DETERMINED
 PATTERN OPENNESS: 63%

SCALE: NONE
 DRAWN: DH
 DATE: 10-18-06
 Q.A.
 COMMENTS

VICTORIAN DESIGN

THIS INFORMATION CONTAINED IN THIS DRAWING IS THE SOLE PROPERTY OF STEELCREST CORPORATION. ANY REPRODUCTION IN PART OR AS A WHOLE WITHOUT WRITTEN PERMISSION OF STEELCREST CORPORATION IS PROHIBITED

PATTERN DETAIL MEASUREMENTS

NOTE: MEASUREMENTS ARE APPROXIMATE AND WILL VARY WITH REGISTER SIZE.

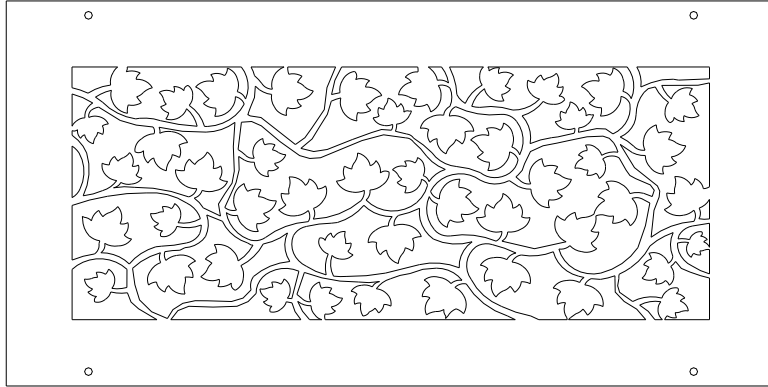
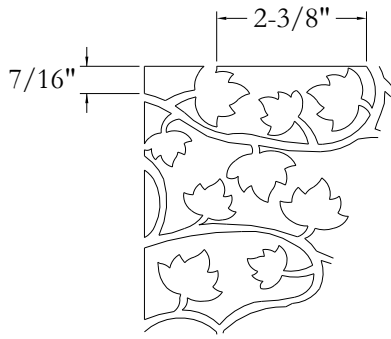

| Air Flow Performance Data | | | | | |
|-------------------------------|-------------|--------------|--------------|---------------|---------------|
| Velocity Static Pressure | 250 0.02 | 500 0.042 | 750 0.063 | 1000 0.084 | 1500 0.126 |
| Size | CFM | | | | |
| 6x6 .25 ft ² | 39 | 77 | 118 | 157 | 232 |
| 8x8 .44 ft ² | 69 | 137 | 207 | 275 | 418 |
| 10x10 .69 ft ² | 108 | 215 | 322 | 432 | 650 |
| 12x12 1.0 ft ² | 157 | 310 | 467 | 620 | 942 |
| 14x14 1.36 ft ² | 213 | 420 | 635 | 845 | 1261 |
| 8x6 .33 ft ² | 52 | 104 | 155 | 207 | 312 |
| 10x6 .42 ft ² | 66 | 130 | 196 | 260 | 388 |
| 12x6 .5 ft ² | 78 | 156 | 235 | 312 | 463 |
| 14x6 .58 ft ² | 91 | 181 | 272 | 365 | 545 |
| 16x6 .67 ft ² | 105 | 207 | 312 | 416 | 620 |
| 18x6 .75 ft ² | 118 | 232 | 350 | 465 | 697 |
| 20x6 .83 ft ² | 130 | 260 | 390 | 515 | 781 |
| 10x8 .56 ft ² | 87 | 172 | 260 | 346 | 520 |
| 12x8 .67 ft ² | 104 | 205 | 312 | 418 | 621 |
| 14x8 .78 ft ² | 122 | 240 | 365 | 482 | 722 |
| 8x4 .22 ft ² | 35 | 69 | 104 | 138 | 207 |
| 10x4 .28 ft ² | 44 | 87 | 130 | 171 | 260 |
| 12x4 .33 ft ² | 52 | 104 | 155 | 205 | 312 |



MATERIAL: 11 GAUGE STEEL
 ABOVE DIMENSIONS ARE IN INCHES
 FINISH: TO BE DETERMINED

PATTERN OPENNESS: 61%

SCALE: NONE
 DRAWN: DH
 DATE: 10-18-06
 Q.A.
 COMMENTS

VINE DESIGN

THIS INFORMATION CONTAINED IN THIS DRAWING IS THE SOLE PROPERTY OF STEELCREST CORPORATION. ANY REPRODUCTION IN PART OR AS A WHOLE WITHOUT WRITTEN PERMISSION OF STEELCREST CORPORATION IS PROHIBITED

PATTERN DETAIL MEASUREMENTS

NOTE: MEASUREMENTS ARE APPROXIMATE AND WILL VARY WITH REGISTER SIZE.

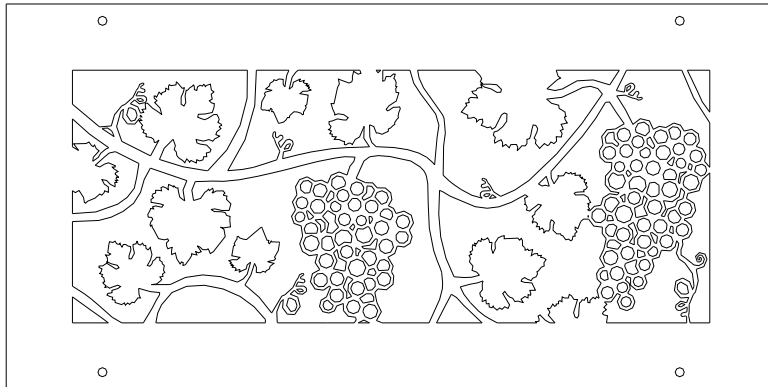
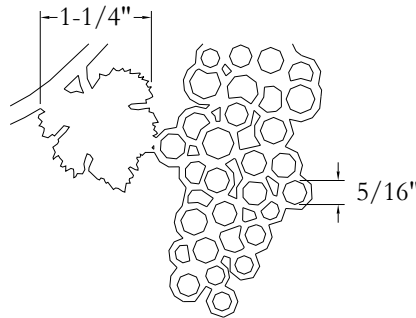

| Air Flow Performance Data | | | | | |
|-------------------------------|-------------|--------------|--------------|---------------|---------------|
| Velocity Static Pressure | 250 0.02 | 500 0.042 | 750 0.063 | 1000 0.084 | 1500 0.126 |
| Size | CFM | | | | |
| 6x6 .25 ft ² | 38 | 75 | 115 | 155 | 230 |
| 8x8 .44 ft ² | 68 | 135 | 205 | 270 | 405 |
| 10x10 .69 ft ² | 105 | 210 | 315 | 425 | 635 |
| 12x12 1.0 ft ² | 155 | 305 | 460 | 610 | 915 |
| 14x14 1.36 ft ² | 211 | 415 | 626 | 830 | 1245 |
| 8x6 .33 ft ² | 52 | 102 | 153 | 203 | 305 |
| 10x6 .42 ft ² | 65 | 127 | 192 | 254 | 381 |
| 12x6 .5 ft ² | 77 | 152 | 230 | 305 | 457 |
| 14x6 .58 ft ² | 90 | 178 | 268 | 356 | 534 |
| 16x6 .67 ft ² | 103 | 203 | 307 | 407 | 610 |
| 18x6 .75 ft ² | 116 | 229 | 345 | 457 | 686 |
| 20x6 .83 ft ² | 129 | 254 | 383 | 508 | 762 |
| 10x8 .56 ft ² | 86 | 169 | 256 | 339 | 508 |
| 12x8 .67 ft ² | 103 | 203 | 307 | 407 | 610 |
| 14x8 .78 ft ² | 121 | 237 | 358 | 474 | 712 |
| 8x4 .22 ft ² | 34 | 68 | 102 | 136 | 203 |
| 10x4 .28 ft ² | 43 | 85 | 128 | 169 | 254 |
| 12x4 .33 ft ² | 52 | 102 | 153 | 203 | 305 |



MATERIAL: 11 GAUGE STEEL
 ABOVE DIMENSIONS ARE IN INCHES
 FINISH: TO BE DETERMINED

PATTERN OPENNESS: 60%

SCALE: NONE
 DRAWN: DH
 DATE: 10-18-06
 Q.A.
 COMMENTS

VINEYARD DESIGN

THIS INFORMATION CONTAINED IN THIS DRAWING IS THE SOLE PROPERTY OF STEELCREST CORPORATION. ANY REPRODUCTION IN PART OR AS A WHOLE WITHOUT WRITTEN PERMISSION OF STEELCREST CORPORATION IS PROHIBITED

PATTERN DETAIL MEASUREMENTS

NOTE: MEASUREMENTS ARE APPROXIMATE AND WILL VARY WITH REGISTER SIZE.

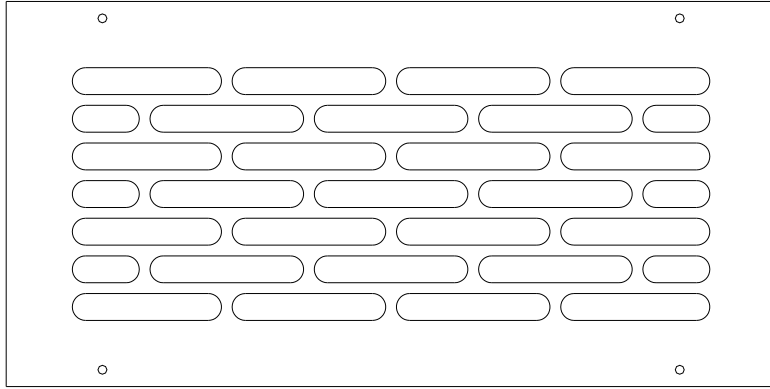
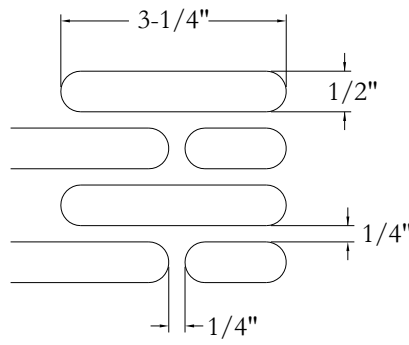

| Air Flow Performance Data | | | | | |
|-------------------------------|--------------|--------------|--------------|---------------|---------------|
| Velocity Static Pressure | 250 0.009 | 500 0.018 | 750 0.027 | 1000 0.036 | 1500 0.055 |
| Size | CFM | | | | |
| 6x6 .25 ft ² | 45 | 92 | 135 | 185 | 275 |
| 8x8 .44 ft ² | 80 | 160 | 240 | 320 | 480 |
| 10x10 .69 ft ² | 125 | 250 | 375 | 500 | 750 |
| 12x12 1.0 ft ² | 180 | 360 | 540 | 720 | 1100 |
| 14x14 1.36 ft ² | 245 | 490 | 735 | 980 | 1470 |
| 8x6 .33 ft ² | 60 | 120 | 180 | 240 | 360 |
| 10x6 .42 ft ² | 75 | 150 | 225 | 300 | 450 |
| 12x6 .5 ft ² | 90 | 180 | 270 | 360 | 540 |
| 14x6 .58 ft ² | 105 | 210 | 315 | 420 | 630 |
| 16x6 .67 ft ² | 120 | 240 | 360 | 480 | 720 |
| 18x6 .75 ft ² | 135 | 270 | 405 | 540 | 810 |
| 20x6 .83 ft ² | 150 | 300 | 450 | 600 | 900 |
| 10x8 .56 ft ² | 100 | 200 | 300 | 400 | 600 |
| 12x8 .67 ft ² | 120 | 240 | 360 | 480 | 720 |
| 14x8 .78 ft ² | 140 | 280 | 420 | 560 | 840 |
| 8x4 .22 ft ² | 40 | 80 | 120 | 160 | 240 |
| 10x4 .28 ft ² | 50 | 100 | 150 | 200 | 300 |
| 12x4 .33 ft ² | 60 | 120 | 180 | 240 | 360 |



MATERIAL: 11 GAUGE STEEL
 ABOVE DIMENSIONS ARE IN INCHES
 FINISH: TO BE DETERMINED

PATTERN OPENNESS: 65%

| | |
|----------|----------|
| SCALE | NONE |
| DRAWN | DH |
| DATE | 10-18-06 |
| Q.A. | |
| COMMENTS | |

VOGUE DESIGN

THIS INFORMATION CONTAINED IN THIS DRAWING IS THE SOLE PROPERTY OF STEELCREST CORPORATION. ANY REPRODUCTION IN PART OR AS A WHOLE WITHOUT WRITTEN PERMISSION OF STEELCREST CORPORATION IS PROHIBITED

PATTERN DETAIL

NOTE: MEASUREMENTS ARE APPROXIMATE AND WILL VARY WITH REGISTER SIZE.
 NO MEDALLIONS WILL EXCEED 8 1/4".
 CHOOSE ANY BACKGROUND DESIGN

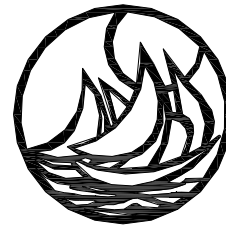
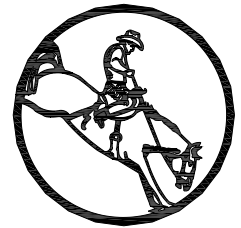
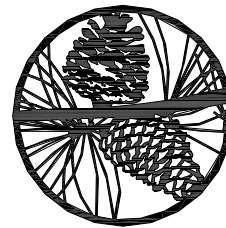

MATERIAL: 11 GAUGE STEEL
 ABOVE DIMENSIONS ARE IN INCHES
 FINISH: TO BE DETERMINED

PATTERN OPENNESS: VARIES

| | |
|----------|----------|
| SCALE | NONE |
| DRAWN | DH |
| DATE | 10-18-06 |
| Q.A. | |
| COMMENTS | |

MEDALLION

THIS INFORMATION CONTAINED IN THIS DRAWING IS THE SOLE PROPERTY OF STEELCREST CORPORATION. ANY REPRODUCTION IN PART OR AS A WHOLE WITHOUT WRITTEN PERMISSION OF STEELCREST CORPORATION IS PROHIBITED

Cabinet, Window, and Door Inserts

Sample Expanded Patterns

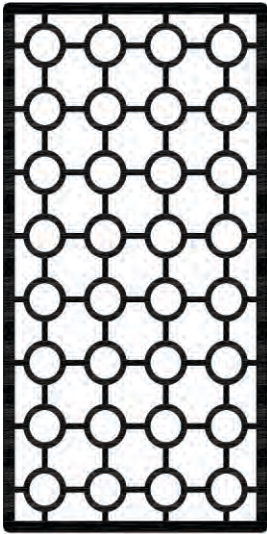

Exp Castle

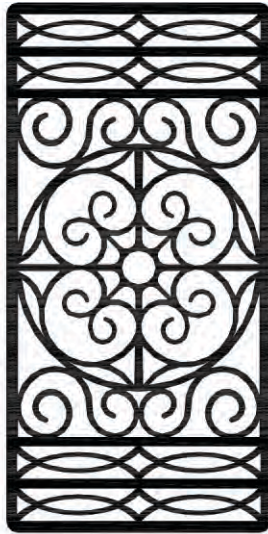

Exp Classic

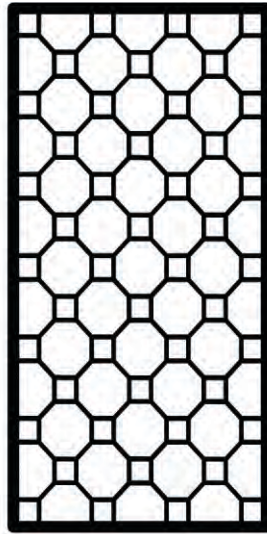

Exp Cobblestone

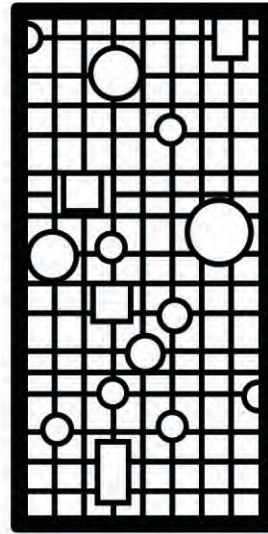

Exp Contemporary



Exp Corinthian

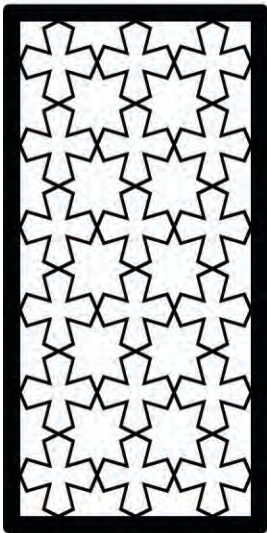

Exp Cobblestone

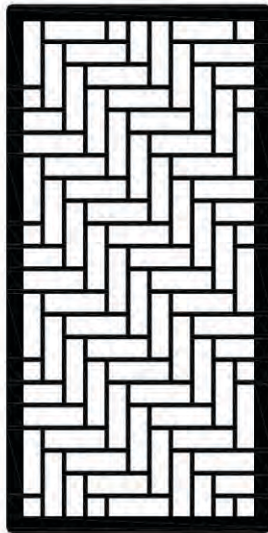

Exp Herringbone

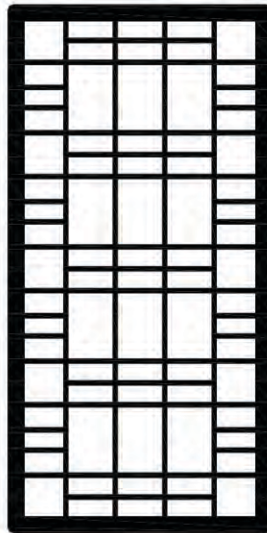

Exp Mission

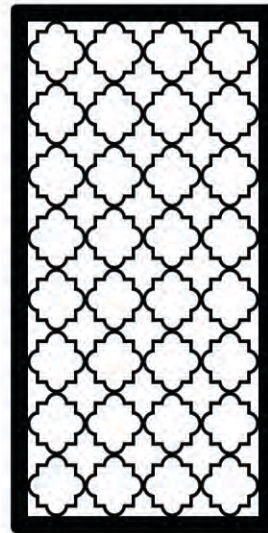

Exp New Classic

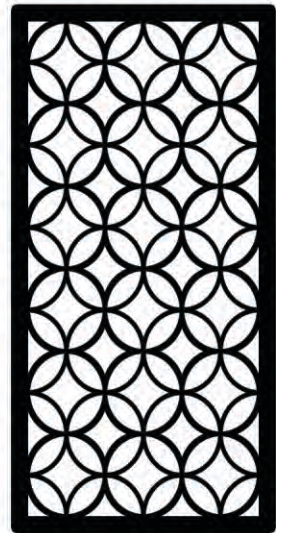

Exp Omni

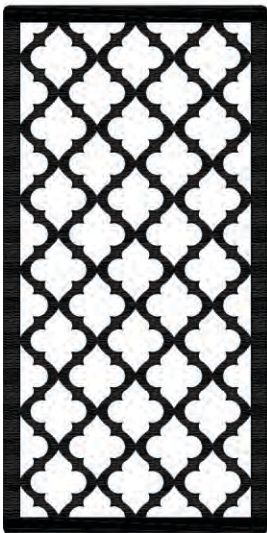

Exp Regency

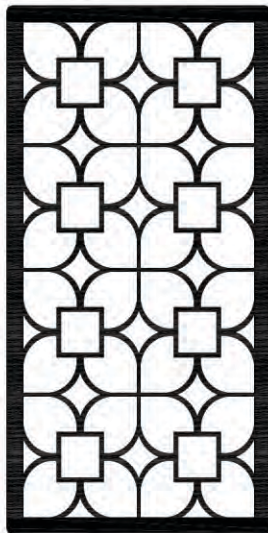

Exp Royal Palm

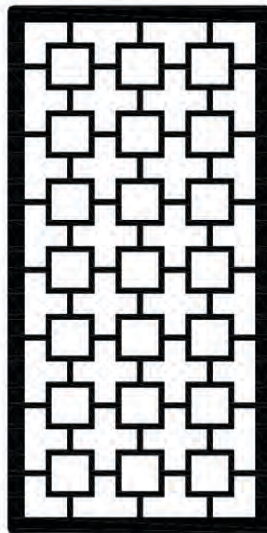

Exp Santa Fe

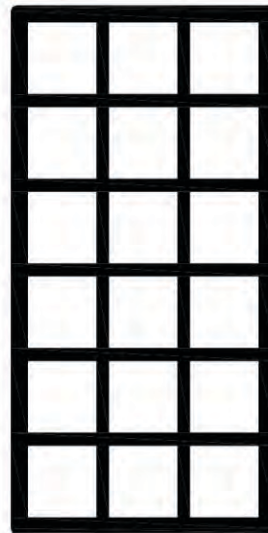

Exp Square

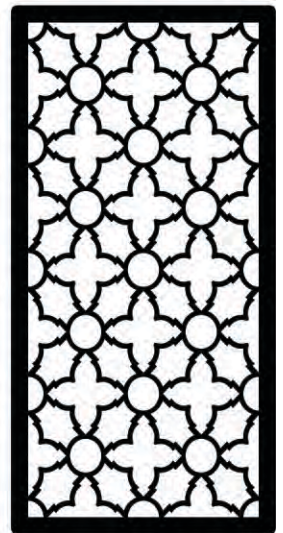

Exp Traditional

* Patterns Represent a 12"x 24" Insert, Pattern layout will vary with size

All inserts come standard in 11 gauge steel, with a powder coated finish, but additional material and finish options are available.

State Outside Dimensions When Ordering.

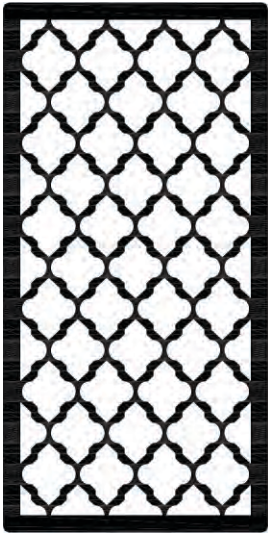

Exp Tuscan



Exp Victorian



Exp Vine



Exp Vinyard

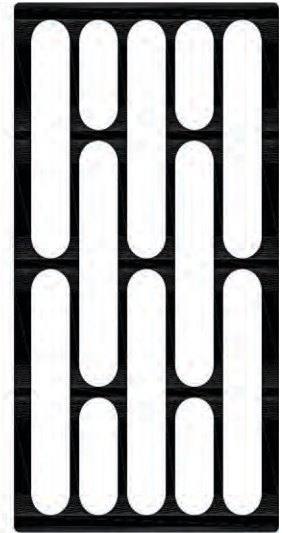

Exp Vogue

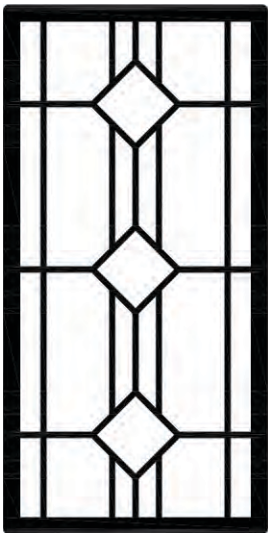

“Anne” Pattern

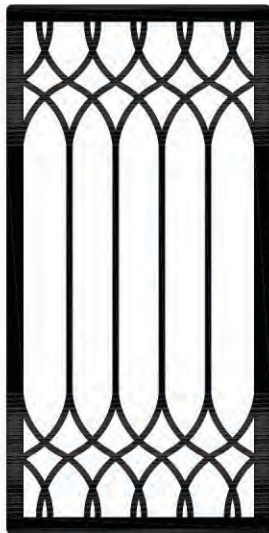

“Ava” Pattern

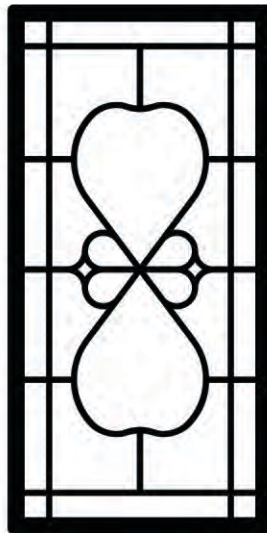

“Cheyenne” Pattern

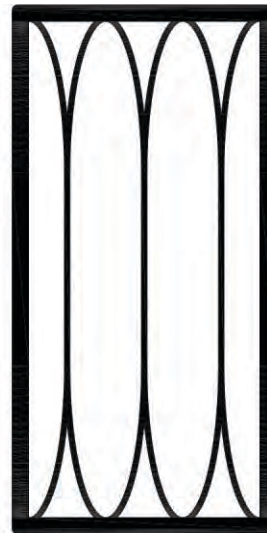

“Grace” Pattern

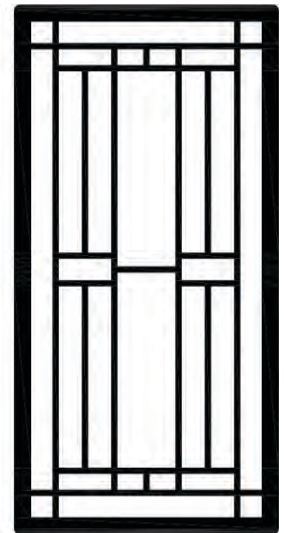

“Marie” Pattern

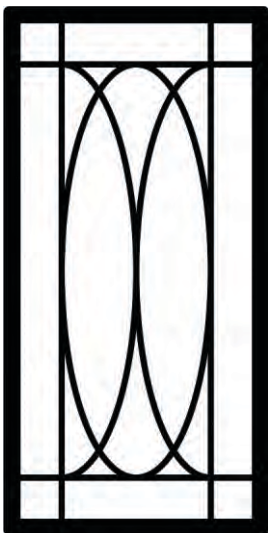

“Monterey” Pattern



* Patterns Represent a 12”x 24” Insert, Pattern layout will vary with size

Floor Grille Guide lines

Best designs for floor use;

- Herringbone
- Omni
- Square
- Stone Wall
- Victorian

Acceptable designs for floor use;

- Castle
- Charleston
- Cobblestone
- Contemporary
- Expo
- Gothic
- Mission
- New Classic
- Presidential
- Pro - Linear
- Pro - Vertical
- Regency
- Royal Palm
- Santa Fe
- Traditional
- Tuscan
- Vintage
- Vogue

Not Acceptable for floor use (customers will need to sign a floor waiver);

- Classic
- Corinthian
- Mountain
- Pinecone
- Renaissance
- Vine
- Vineyard

Extra Strapping: (Steel bars welded across the back of the design for strength)

- Recommended for any floor grille that is over 10” in the narrowest direction i.e.; 20x10 would need extra strapping but 20x4 would not.
- Bars will be visible through the design; Steelcrest will hide the bars behind the design if possible.
- The number of bars will vary depending on size and design
- If a Concealment Louver is needed on a part with extra strapping adds \$25 to price.

Thicker Material: (Beveled edges are always recommended with thicker material)

- 3/16” is recommended on any grilles in high traffic areas or when extra strapping is not acceptable. In general any grille over 10” in the narrowest direction should have either 3/16” material or extra strapping and any grill 14” or larger should have both.
- 1/4" is recommended when grilles are 14” or larger and extra strapping is not acceptable. 1/4" is also a good solution for very high traffic areas
- 3/8” is recommended for commercial applications or in any application that will have vehicular traffic. If heavy vehicular traffic is expected (forklifts or commercial trucks) extra strapping or 1/2' may be needed.

Filter Grilles:

- Standard SteelCrest return air filter frames are not designed for floor use.
- SteelCrest can add a filter rack to the back of any floor return to hold an air filter(+\$25)
 - Filter racks will not work with extra strapping.

HOW TO MEASURE

1. If possible, remove the existing register or grille.
2. Measure the actual opening in the wall, ceiling, or floor: important to measure WIDTH" x HEIGHT"
3. If the rough opening measures 20 inches wide by 14 inches tall, the correct size piece to order would be a 20"x14".
4. The actual register or grille's interior dimensions will be slightly smaller, so the piece's frame and damper assembly fit into the recessed opening.
5. The actual register or grille's size including flange will be larger. This will ensure the flange will fit flush on the finished surface and completely cover the rough opening. This outer flange will house the various screw holes to securely attach the register or grille.
6. SteelCrest manufactures products to fit any size opening. You tell us the opening size and we'll take it from there!
7. If the existing register or grille can't be removed, measure the outside of the existing piece and call for assistance.
8. Before installing your register or grille, we recommend painting the interior of the opening with flat black paint to ensure a clean finished look.

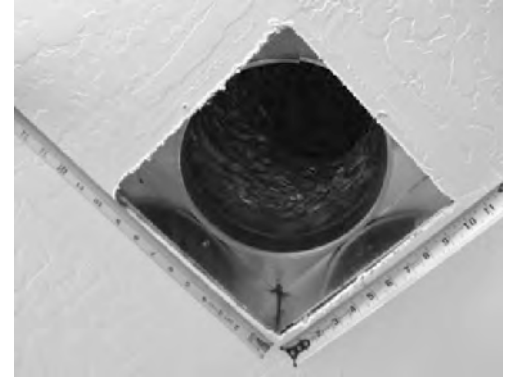

HOW TO ACHIEVE "THE PERFECT FIT"

General Overview

- Pattern direction is dictated by stated opening size. Width then Height
- Pattern size is always $\frac{3}{4}$ " smaller than stated register size, e.g. 12"x4" = 11.25" x 3.25"
- All measurements are accurate to 0.1" unless the customer states they need more accuracy
- Standard screw size #8 x 1 $\frac{3}{4}$ " and are counter sunk into the face of the register
- Frame OD size is $\frac{3}{8}$ " smaller than stated size overall, e.g. 14"x6" is 13 $\frac{5}{8}$ " x 5 $\frac{5}{8}$ " frame OD
- Frames are:
 - $\frac{3}{4}$ " deep without a damper
 - 2 $\frac{1}{4}$ " deep with damper

Flange

- If the register is 4" across narrowest width or smaller; Flange size is $\frac{3}{4}$ " on each side of register to equal 1 $\frac{1}{2}$ " larger than stated size e.g. 24" x 4" = 25.5" x 5.5" OD
- If the register is between 4.5" wide to 13.5" wide); Flange size is 1" on each side of register to equal 2" larger than the stated size e.g. 24" x 12" is 26" x 14" OD
- All registers wider than 14"; Flange size is 1 $\frac{1}{4}$ " on each side of register to equal 2 $\frac{1}{2}$ " larger than the stated size e.g. 15" x 15" is 17.5" x 17.5" OD
- All WF = $\frac{1}{2}$ " larger than sizes above; SF = $\frac{1}{2}$ " smaller than sizes above

RAFF's

- 2 $\frac{1}{4}$ " deep and match stated opening size exactly
- Duct opening sizes are typically oversized by the builder, as much as $\frac{1}{2}$ "
- RAFF's are built to open according to size, e.g. 40" x 20" will hinge along the 40" side; 20" x 40" will hinge along the 20" side

Floor Registers

- Patterns that are not recommended for "high traffic" floor registers are:

| | |
|------------|----------------------------|
| • Classic | • Renaissance |
| • Vineyard | • Corinthian |
| • Vine | • Or any of the medallions |
- High traffic registers that are larger than 20" x 10" should be $\frac{3}{16}$ " or thicker, depending on the pattern.

Access Panels

- All access panels will be constructed of 14 gauge steel
- Frame OD will be $\frac{3}{8}$ " smaller than stated size, e.g. 14"x14" will have a frame OD of 13 $\frac{5}{8}$ "x 13 $\frac{5}{8}$ "
- Access panel frames are 2" deep
- Mounting holes in the frame
- Option: With or without backer
- Option: Ornamental or standard flange

SteelCrestOnline.com



The information presented in this guide may be subject to change and is not intended to be a warranty of product construction or performance. How to Measure and How to Achieve the Perfect Fit information is suggestive for optimal circumstances and may not be applicable to all environments. SteelCrest Registers & Grilles will not be responsible or liable for errors resulting from the use, or reference to this guide. Please contact SteelCrest Registers & Grilles with any questions.