

Curved Blade Register – Two Way

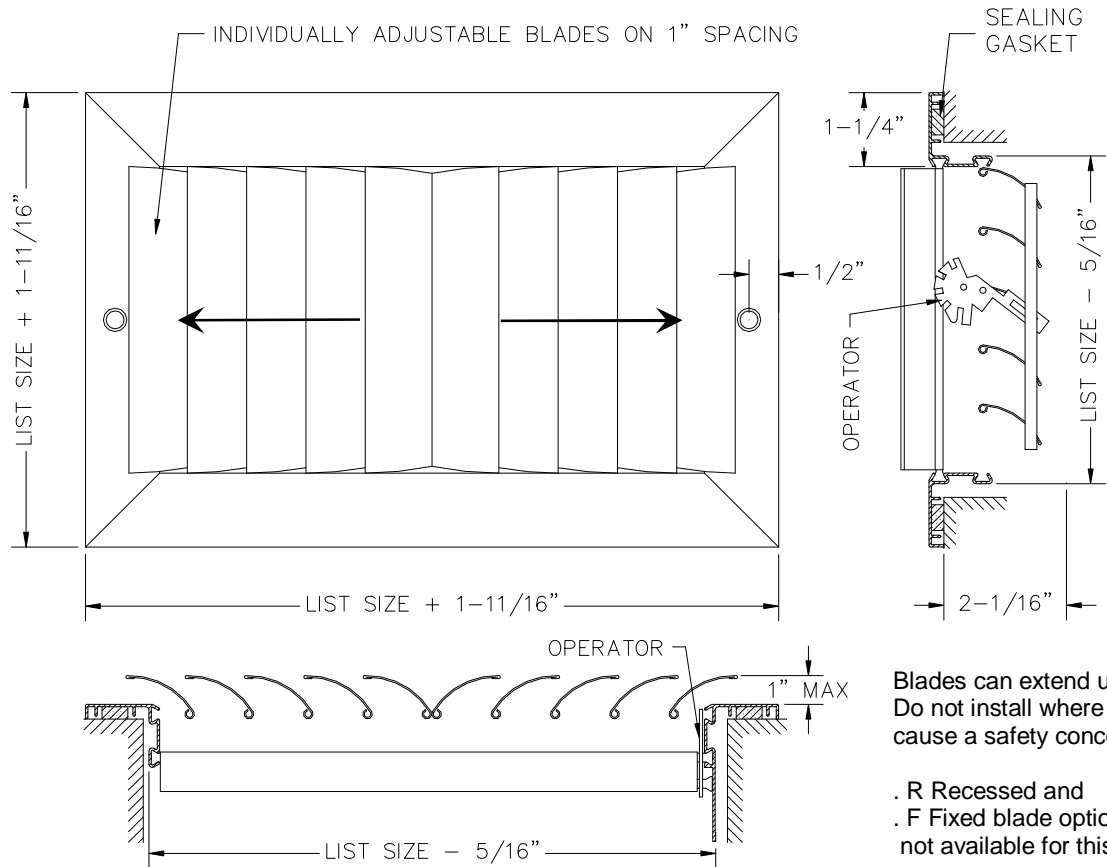

DAC2VM

- Two way individually adjustable vertical curved blades on 1+ spacing allows a wider spread of air to be achieved
- Multi-Shutter Damper with handle operator
- Rollformed aluminum blade installed in an extruded aluminum frame with mechanically locked corners
- Pressure fit nylon pivot pins (rattle free & non loosening)
- Countersunk screwholes c/w painted mounting screws
- Sealing gasket to prevent steaking of walls or ceiling
- Available on 2+increments as standard
- Custom sizes available but extra charge may apply
- Max blade length is 22+ Mullions used for larger sizes
- Durable powdercoat painted finish
- Available in White, Silver or Mill



Blades can extend up to 1+
Do not install where it may cause a safety concern.

. R Recessed and
. F Fixed blade options
not available for this model



| DESCRIPTION | DAC2VM |
|-------------|---------------------|
| FACE BLADES | Vertical Adjustable |
| REAR BLADES | n/a |
| DAMPER | Multi-Shutter |
| MATERIAL | Aluminum |
| COLOR | White/Silver/Mill |

| | |
|-------------|-------|
| JOB NAME: | _____ |
| LOCATION: | _____ |
| ARCHITECT: | _____ |
| ENGINEER: | _____ |
| CONTRACTOR: | _____ |