

Curved Blade Register – One Way

DAC1VM

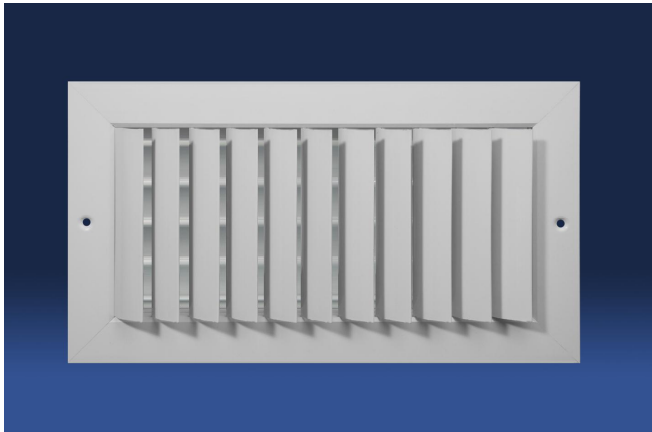

- One way individually adjustable vertical curved blades on 1+ spacing allows a wider spread of air to be achieved
- Multi-Shutter Damper with handle operator
- Rollformed aluminum blade installed in an extruded aluminum frame with mechanically locked corners
- Pressure fit nylon pivot pins (rattle free & non loosening)
- Countersunk screwholes c/w painted mounting screws
- Sealing gasket to prevent steaking of walls or ceiling
- Available on 2+increments as standard
- Custom sizes available but extra charge may apply
- Max blade length is 22+ Mullions used for larger sizes
- Durable powdercoat painted finish
- Available in White, Silver or Mill

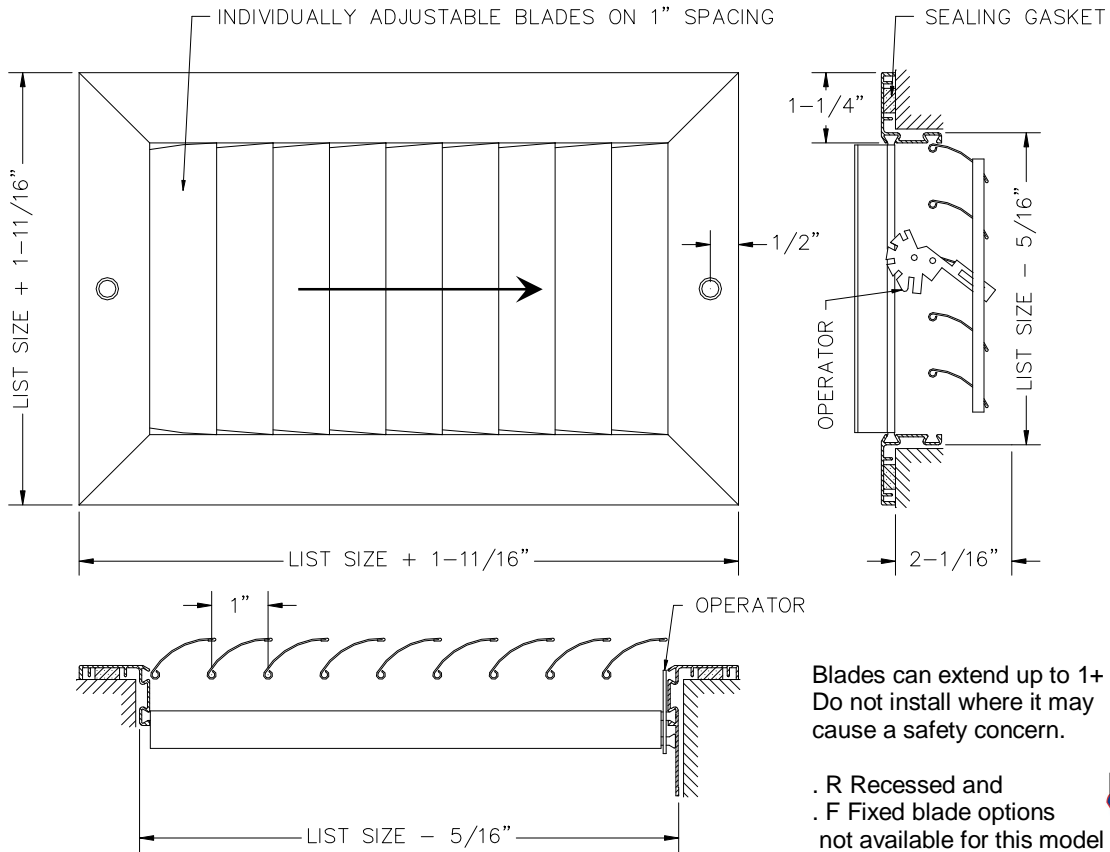

DESCRIPTION	DAC1VM
FACE BLADES	Vertical Adjustable
REAR BLADES	n/a
DAMPER	Multi-Shutter
MATERIAL	Aluminum
COLOR	White/Silver/Mill

JOB NAME:	_____
LOCATION:	_____
ARCHITECT:	_____
ENGINEER:	_____
CONTRACTOR:	_____