

Non-Vision Door Grilles

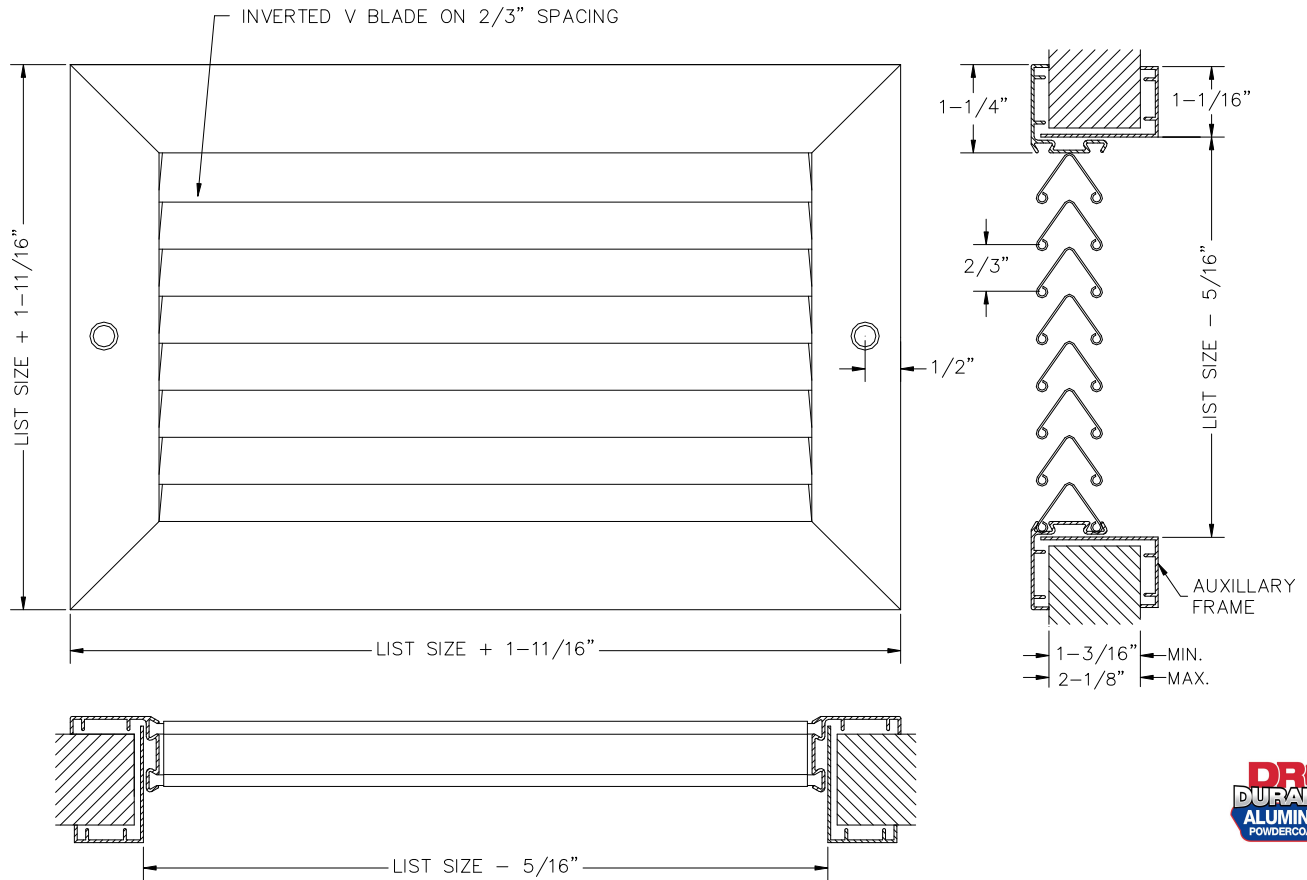

DANV-A

- Inverted V rollformed blades on 2/3" spacing providing a stylish appearance on both sides
- Pressure fit nylon pivot pins . rattle free & non loosening
- Aluminum extruded frame with mechanically locked corners
- Aluminum extruded auxiliary trim frame for opposite side provided (fits doors 1³/₁₆" to 2¹/₈" thick)
- Countersunk screwholes c/w painted mounting screws
- Custom sizes available but extra charge may apply
- Max blade length is 22+ Mullions used for larger sizes
- Durable powdercoat painted finish
- Available in White, Silver or Mill



DESCRIPTION	DANV-A
FACE BLADES	Horizional Inverted V Blade
REAR BLADES	n/a
DAMPER	n/a
MATERIAL	Aluminum
COLOR	White/Silver/Mill

JOB NAME: _____

LOCATION: _____

ARCHITECT: _____

ENGINEER: _____

CONTRACTOR: _____