

2" Storm Proof Louver

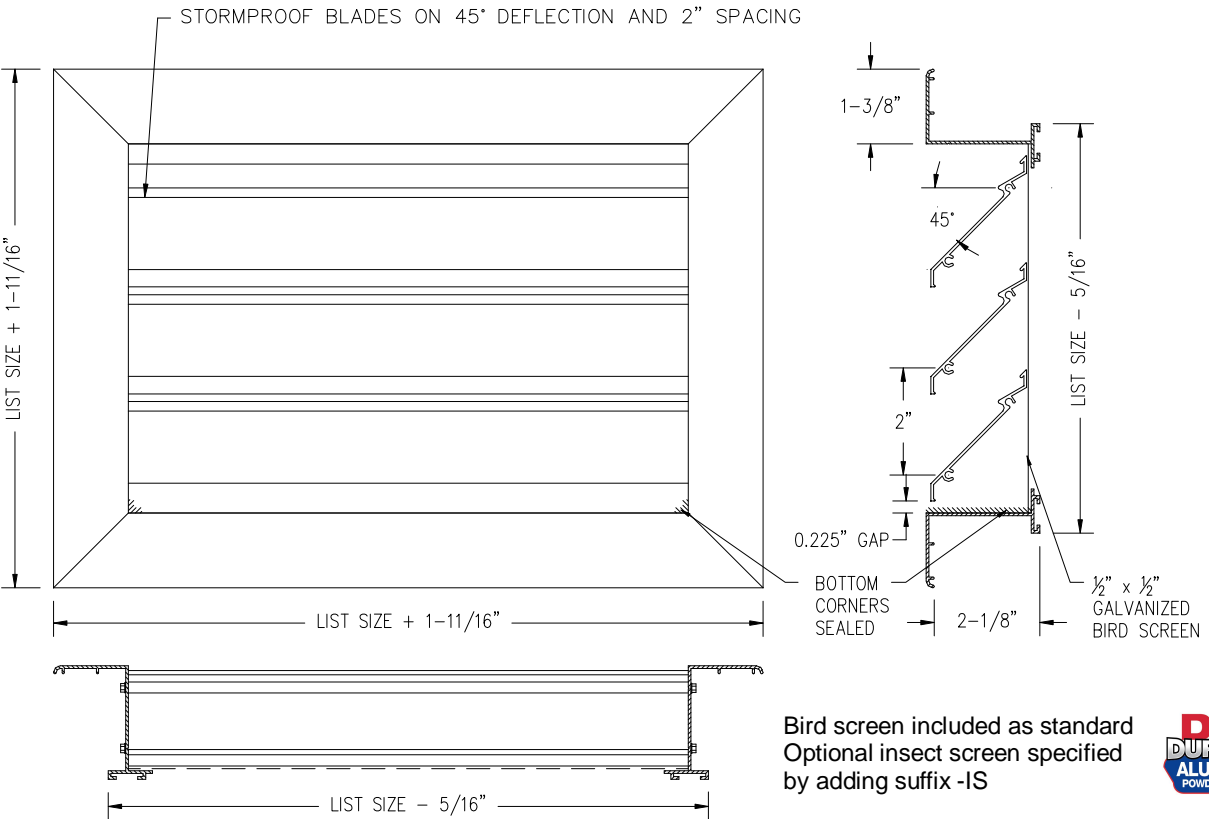

DAL2-FF

- Extruded Stormproof blades on 2+spacing designed to prevent water infiltration while maximizing free area
- Heavy-duty aluminum extruded frame with mechanically locked mitre corners for outside use
- Available on 1+increments as standard
- Any size available but extra charge may apply, min. size 6+
- Max blade length is 36+ Mullions used for larger sizes
- Larger pieces are manufactured in sections and provided with aligning pins for ease of installation on jobsite
- Bird screen included as standard. Insect screen optional.
- Available in Mill as standard. Durable powdercoat painted White, Silver or Brown finishes are also available



Bird screen included as standard
Optional insect screen specified by adding suffix -IS



DESCRIPTION	DAL2-FF
FACE BLADES	45° Storm Proof
THICKNESS	0.050+
SCREEN	Bird Screen
MATERIAL	6063-T5 Extruded Aluminum
COLOR	White/Silver/Brown/Mill

JOB NAME: _____

LOCATION: _____

ARCHITECT: _____

ENGINEER: _____

CONTRACTOR: _____