

Thin Line Louvers

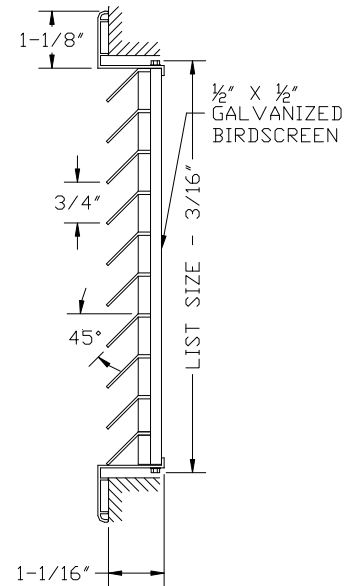

DALTL-45

- Horizontal blades fixed on 45° deflection and 3/4" spacing
- Extruded aluminum blades designed for high efficiency
- Aluminum extruded supports hidden behind for a continuous clean appearance. No face mullions.
- Aluminum extruded frame with mechanically locked corners
- Available on 1+increments as standard, min size 3+
- Maximum width 78+, maximum height is 60+
- Custom sizes available but extra charge may apply
- Bird screen included as standard. Insect screen optional.
- Available in Mill as standard. Durable powdercoat painted White, Silver or Brown finishes are also available

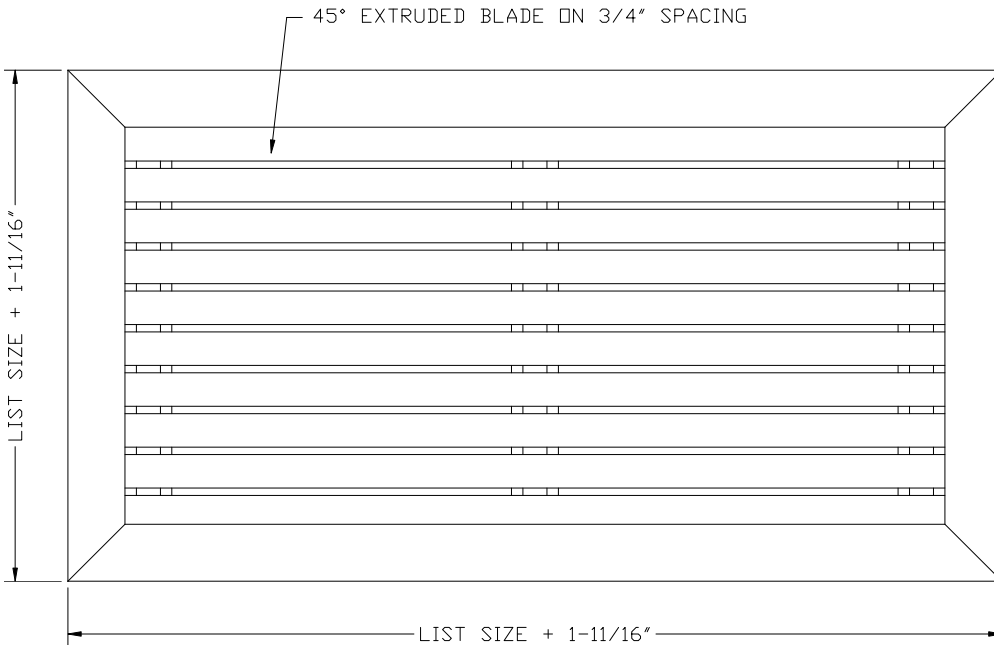

Bird screen included as standard
Optional insect screen specified by adding suffix -IS

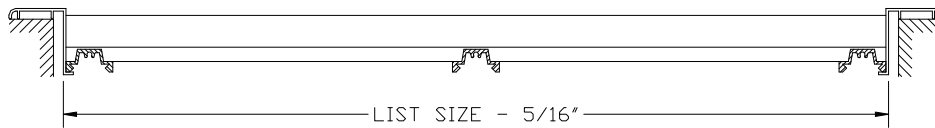

DESCRIPTION	DALTL-45
FACE BLADES	45° Extruded Blades
THICKNESS	0.050+to 0.070+
SCREEN	Bird Screen
MATERIAL	6063-T5 Extruded Aluminum
COLOR	White/Silver/Brown/Mill

JOB NAME: _____

LOCATION: _____

ARCHITECT: _____

ENGINEER: _____

CONTRACTOR: _____