

# Return Air Register

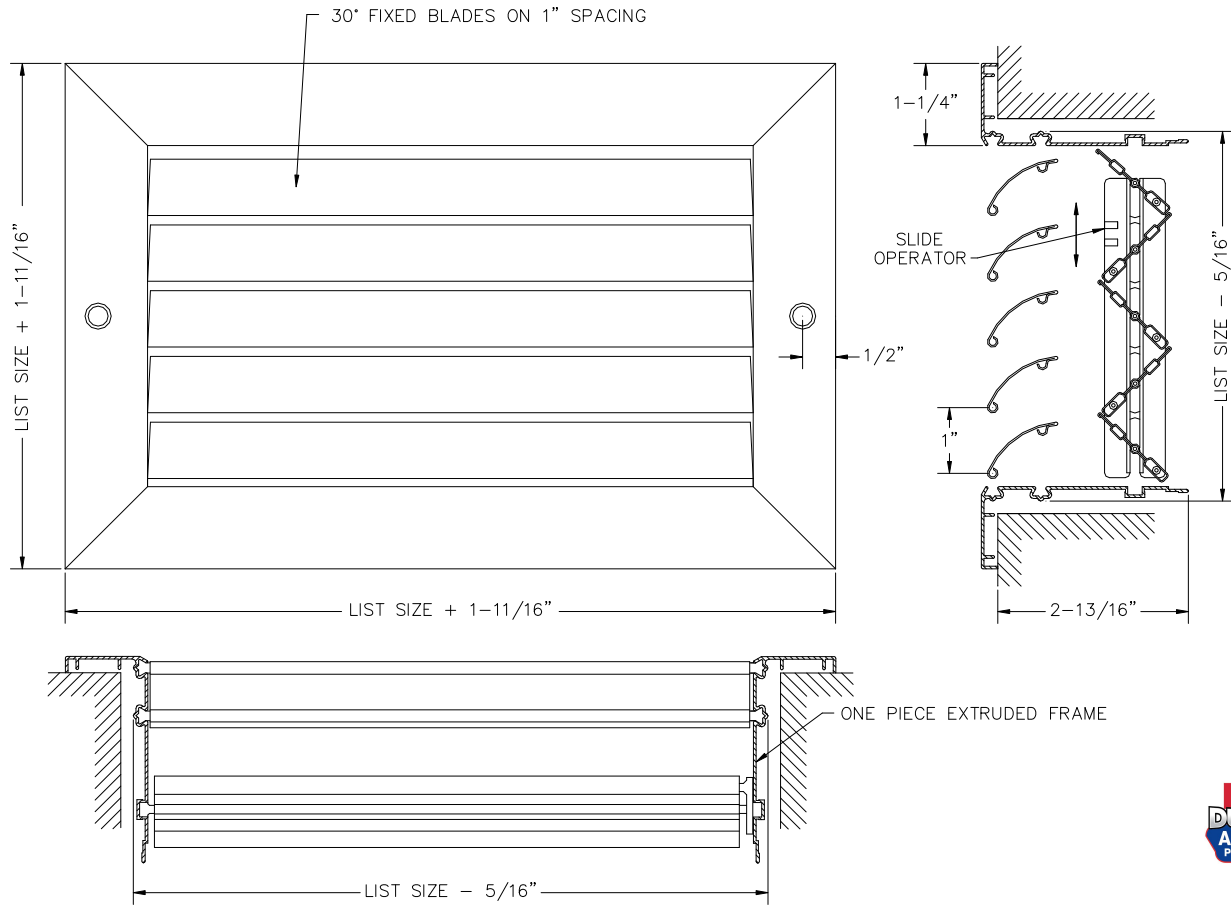

## DARH1D

- Horizontal blades fixed on 30° deflection and 1+spacing
- Opposed Blade Damper with slide operator
- Aluminum rollformed blades provide a stylish appearance
- Pressure fit nylon pivot pins (rattle free & non loosening)
- Aluminum extruded frame with mechanically locked corners
- Countersunk screwholes c/w painted mounting screws
- Available on 2+increments as standard
- Custom sizes available but extra charge may apply
- Max blade length is 22+ Mullions used for larger sizes
- Durable powdercoat painted finish
- Available in White, Silver or Mill



DESCRIPTION	DARH1D
FACE BLADES	Horizontal Fixed 30°
REAR BLADES	n/a
DAMPER	Opposed Blade
MATERIAL	Aluminum
COLOR	White/Silver/Mill

**JOB NAME:** \_\_\_\_\_

**LOCATION:** \_\_\_\_\_

**ARCHITECT:** \_\_\_\_\_

**ENGINEER:** \_\_\_\_\_

**CONTRACTOR:** \_\_\_\_\_