

Return Air Grille

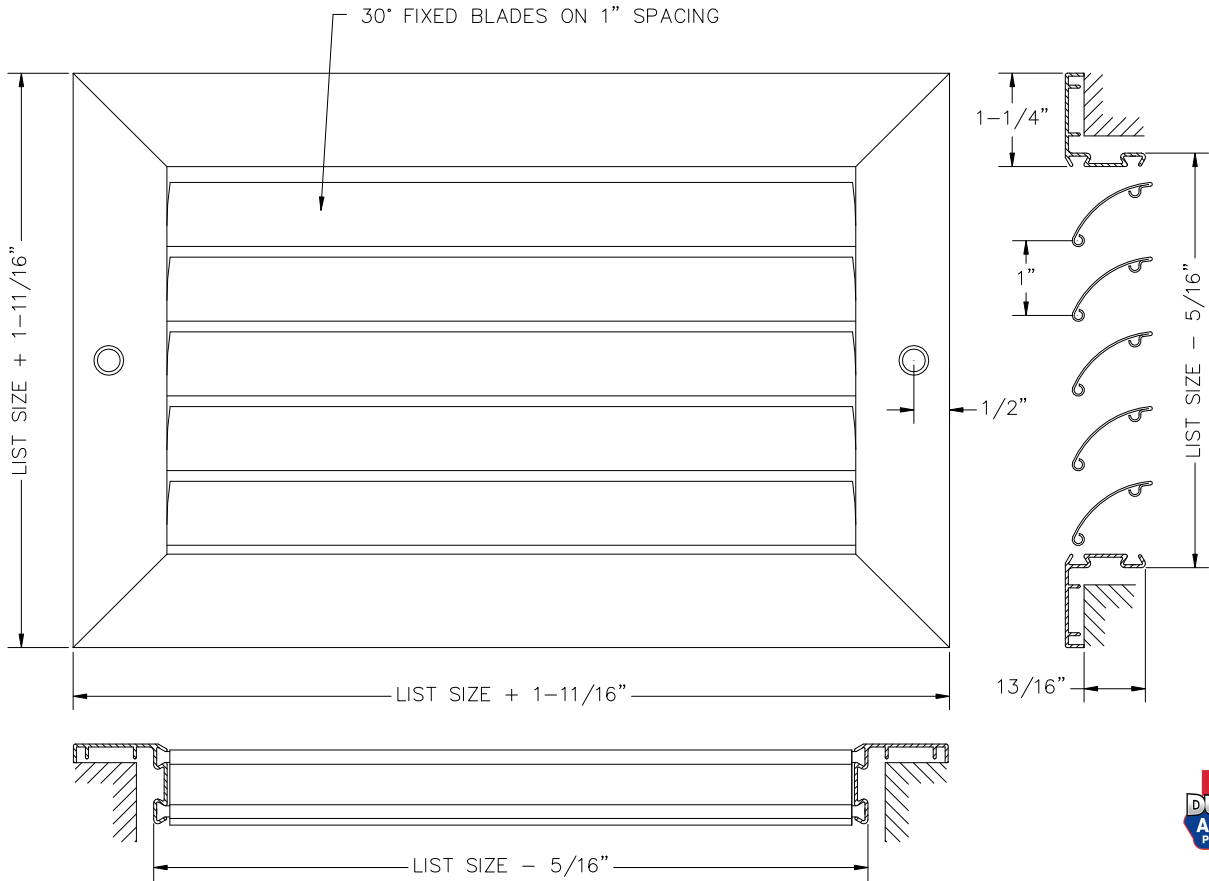

DARH1

- Horizontal blades fixed on 30° deflection and 1+spacing
- Aluminum rollformed blade providing a stylish appearance
- Pressure fit nylon pivot pins (rattle free & non loosening)
- Aluminum extruded frame with mechanically locked corners
- Countersunk screwholes c/w painted mounting screws
- Available on 2+increments as standard
- Custom sizes available but extra charge may apply
- Max blade length is 22+ Mullions used for larger sizes
- Durable powdercoat painted finish
- Available in White, Silver or Mill



DESCRIPTION	DARH1
FACE BLADES	Horizontal Fixed 30°
REAR BLADES	n/a
DAMPER	n/a
MATERIAL	Aluminum
COLOR	White/Silver/Mill

JOB NAME: _____

LOCATION: _____

ARCHITECT: _____

ENGINEER: _____

CONTRACTOR: _____